

RADIO RETAILING

HOME ENTERTAINMENT MERCHANDISING

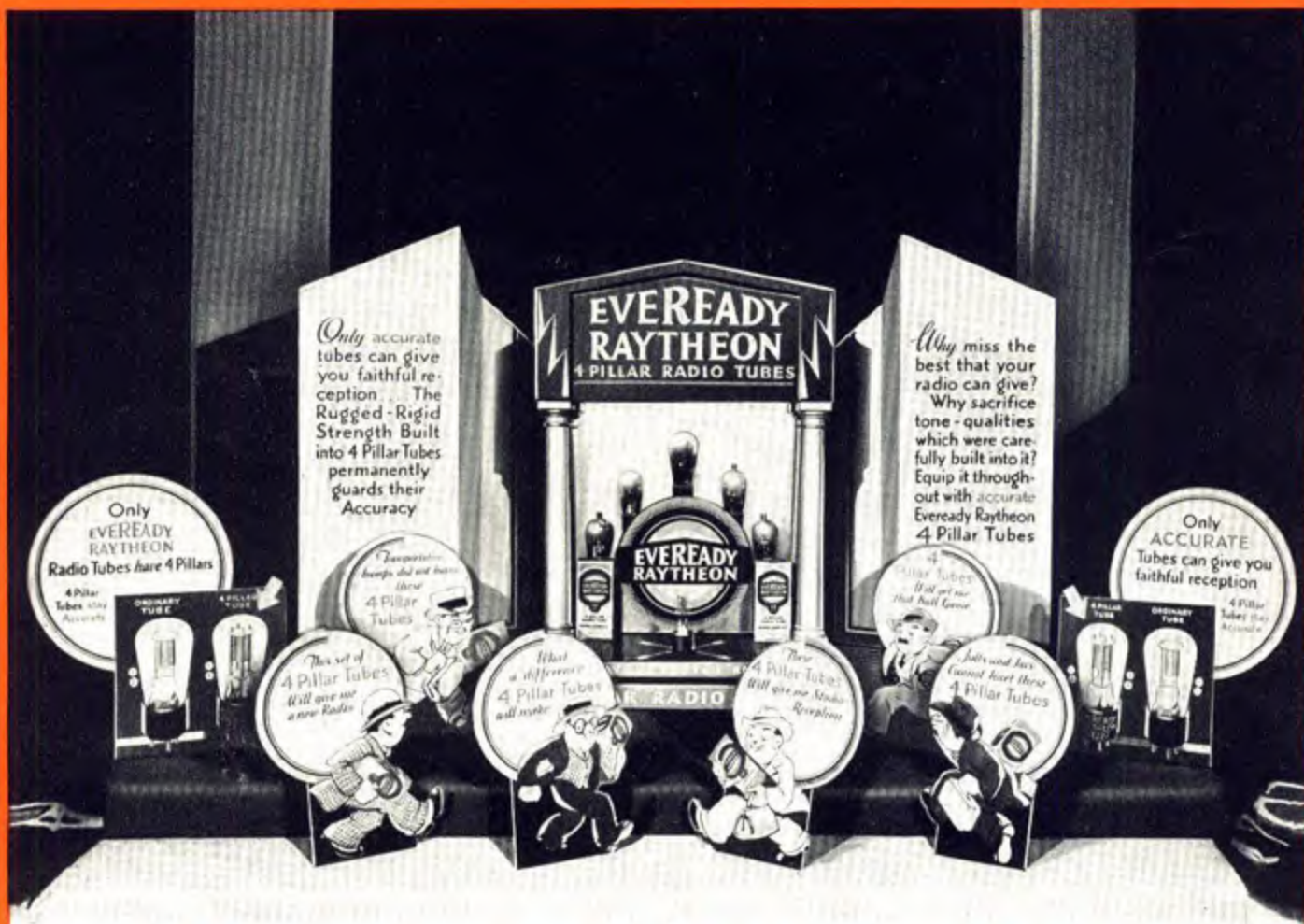

MONEY IN YOUR WINDOW

THERE'S still time for you to enter the Eveready Raytheon \$5000 Prize Contest! Five thousand United States dollars will be distributed for the best windows displaying four-pillar tubes. 218 prizes in all, with the first prize starting at \$500!

Window must be installed week of September 25. Photographs of windows must be mailed by

October 15. Ask your jobber salesman, or write the National Carbon Company, for complete details.

NATIONAL CARBON COMPANY, INC.
General Offices: New York, N. Y.

Branches: Chicago New York San Francisco
Unit of Union Carbide  and Carbon Corporation

EVEREADY RAYTHEON

4-PILLAR RADIO TUBES

Mightiest of all

Clarion



triumphs

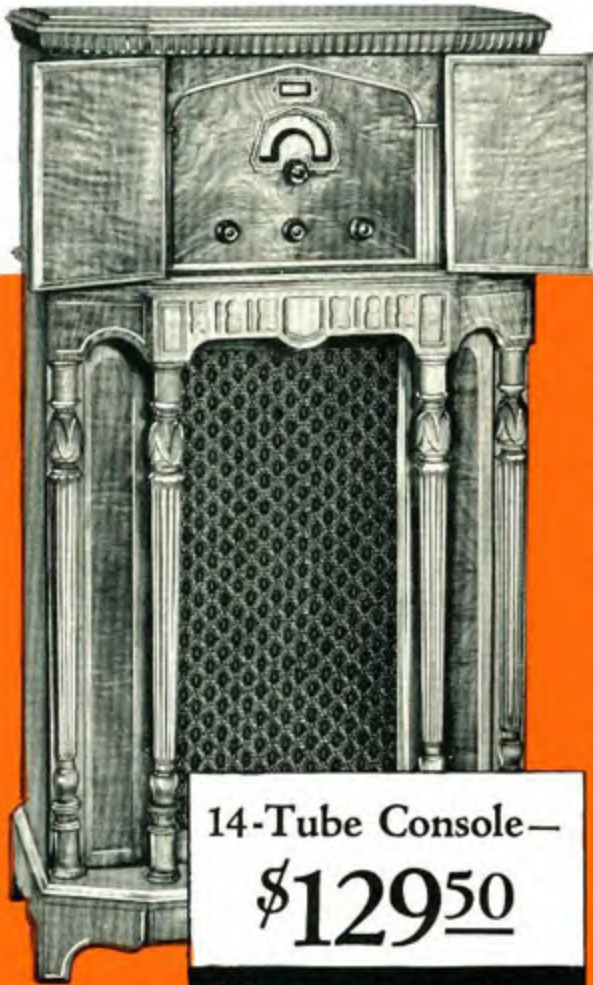

... the 14-Tube DeLuxe Console

The easiest-to-sell line in the industry brings out a new selling argument—a 14-tube sensation! As far ahead in price and performance appeal as you expect the leader of the Clarion line to be. What a radio!

- Price includes Federal Tax.
- 14 new type tubes.
- Class B amplification giving 20 watts of undistorted audible power.
- Tuning indicator allowing silent tuning and insuring perfect reproduction.
- Two over-sized 10-inch speakers designed to reproduce faithfully low and high notes at minimum volume.
- Double-twin audio system.
- Three audio stages.
- Delayed automatic volume control.
- Variable noise level control eliminating noise between stations.
- Continuous variable tone control.
- Twin diode detector with separate automatic volume control tube.
- Clar-acoustic automatic frequency compensation impressing same tonal sensation on the human ear at all volume levels.
- Automatic selectivity control, giving great depth and brilliance to reception on powerful stations.
- New full-vision dial.
- Battleship-constructed chassis, completely shielded.
- Acoustically engineered cabinet with large baffle area to insure accurate interpretation of all instruments and voices.
- Tube complement: 1—No. 82; 2—No. 46's; 4—No. 58's; 7—No. 56's.
- Radio's finest cabinet, Heppelwhite design, with two doors enclosing instrument panel. Pilasters with inlaid marquetry. The sounding board recedes from four carved and beaded columns which gives the effect of cathedral grace.
- Dimensions: 44½ inches high, 25 inches wide, 14 inches deep.

14-Tube Console—
\$129⁵⁰

The radio with
98%
pure tone

Write your jobber at once
for the *special merchandising*
plan on this new
money-maker.



Model 280
12-tube Console
\$73⁹⁵
Complete



Model 240
8-tube Midget
\$41⁹⁵
Complete



Model 220
6-tube Midget
\$31⁹⁵
Complete

Model 260
10-tube Console
\$52⁹⁵
Complete



Prices slightly higher in the Far West and South. All prices tax paid.

TRANSFORMER CORPORATION OF AMERICA, Ogden and Keeler Avenues, CHICAGO, ILL.

**AMERICAN BOSCH
VIBRO-POWER RADIO LINE**

All prices complete with tubes, U. S. tax paid. All AC console models equipped with twin speakers.

THE GRAND OPERA—Model 312G. Vibro-Power 12 tube triple action superheterodyne in cabinet de luxe. \$178.95.

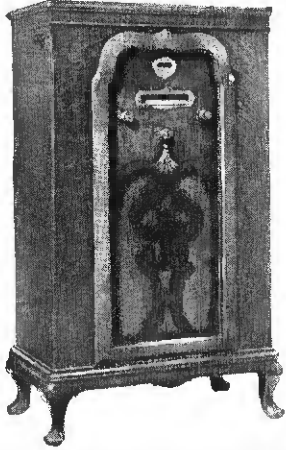

THE GRAND CONCERT—Model 312C. Vibro-Power 12 tube triple action superheterodyne. \$147.95.

THE WORLD CRUISER—Model 260C. Vibro-Power 10 tube double action multi-wave superheterodyne, in cabinet de luxe, for long and short wave broadcasts. \$132.95.

THE WORLD ROVER—Model 260R. Vibro-Power 10 tube double action multi-wave superheterodyne, for long and short wave broadcasts. \$105.95.



THE MANSION—Model 250M. Vibro-Power 10 tube double action superheterodyne. \$95.95.

THE FIRESIDE—Model 226F. Vibro-Power 8 tube superheterodyne Air Cell receiver. \$99.95

THE METROPOLITAN—Model 224D. Vibro-Power 8 tube superheterodyne for DC current. \$84.95.

THE EMPIRE—Model 242E. Vibro-Power 8 tube double action superheterodyne. \$74.95.

PERSONAL RADIO CHESTS—Models 200A and B. Equipped with police signal switch. \$49.95.

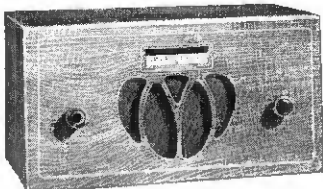

PERSONAL RADIO—Model 236A. New 6 tube superheterodyne. \$45.95.

PERSONAL RADIO—Model 205A. New 5 tube set. \$34.95. With Police Switch, \$39.95.

MOTOR CAR RADIO—Model 100. \$85.90 including Magmotor.

VIBRO-POWER

*-the newly discovered
SUPER-FORCE in RADIO!*

sets greatest values,
by actual check-up

YOU have heard only half the amazing story of Vibro-Power when you listen to an American Bosch Vibro-Power Radio... thrill to its dazzling clear tone... wonder at its fool-proof operation... marvel at its unparalleled control over unwanted noise and static.

Equally as sensational are the values Vibro-Power now makes possible. The prices throughout the entire American Bosch Vibro-Power line are actually lower than the average radio set on the market today.

Here is an actual price comparison of competitive radio sets at the Annual Radio Show... it is a revelation in 1933 radio values:

No. of tubes	No. of sets at Chicago	Average price with tax added	Price of American Bosch Vibro-Power Radio with U.S. Tax Paid
5 tubes	28	\$ 37.44	\$34.95 Personal
6 "	23	54.99	45.95 Personal
8 "	36	76.91	74.95 Empire
10 "	30	138.25	95.95 Mansion
11 " up	27	158.39	147.95 Grand Concert

Vibro-Power, the Newest Force in Radio! Prices below the average in every classification! A complete line for every purse or purpose. Made by a manufacturer with 40 years' background in precision electrical products. American Bosch gives you more to make money on than any other line. Send for new rotogravure broadside.

UNITED AMERICAN BOSCH CORP., SPRINGFIELD, MASSACHUSETTS

Branches: New York Chicago Detroit San Francisco

Manufactured under patents and applications of R C A

AMERICAN BOSCH VIBRO-POWER RADIO

If you were building a RADIO for Yourself.....



YOU WOULD select tested circuits—use only full weight fine materials—install the best parts that money could buy—if you built your own radio—yourself.

When completed, you would be proud of your radio. You would revel in its fine tone—its superior operation—and above all, the permanence of these qualities.

Every Stromberg-Carlson is “custom-built” to these same standards. That is why Stromberg-Carlson owners are proud of their radios and influence their friends to buy only Stromberg-Carlsons.

And, that is why dealers handling this quality line enjoy a constantly growing business in profitable units of sale—and are free from the expensive servicing that inevitably follows “quantity production” radios.

*Stromberg-Carlsons are priced from \$143 to \$407.50.
Telektor types from \$310 to \$567.50. (East of Rockies.)*

STROMBERG-CARLSON TELEPHONE MFG. CO.
ROCHESTER, N. Y.

The Condensers (capacitors) used in Stromberg-Carlson Radios are the same paper-wound type that Stromberg-Carlson uses in its telephone switchboards. They are much larger and much more expensive than the condensers commonly used in radios, but they are the only type that will give satisfactory results, indefinitely.



1894

Stromberg-Carlson

MAKERS OF VOICE TRANSMISSION AND VOICE RECEPTION APPARATUS FOR MORE THAN THIRTY-FIVE YEARS



1932

USE THIS POSTER AND
...YOU'RE ELECTED



to bigger quicker tube sales!

MOTHER may be a Democrat and Father a Republican... but the family votes solid on one thing—they want their set in A-1 order for the political speeches and election returns.

That's why this cartoon poster on politics is a good tube salesman for your store. Put it in the window... watch people stop—smile—and buy!

Look in the ballot box at the right! Note the descriptions of other FREE posters and counter cards that you can have for the asking. Cast your vote for more tube sales. Other dealers have done it—and gotten as high as ninety per cent increased sales!

In addition, Sylvania backs you up with continued broadcasts—newspaper advertising—by a special no-cost Tube Analyzer Plan and a no-cost Service Kit Plan. Ask for details.

Sylvania
REGISTERED U.S. PAT. OFF.
THE SET-TESTED TUBE

**THE SYLVANIA
 BETTER BUSINESS BALLOT**

More Sales Platform

FIRST PLANK

Politics are the talk of the season! More political speeches than ever before are on the air, more families listening in. This poster makes election fans want new tubes. Size 12x28.

SECOND PLANK

People always stop for pictures! This 38 x 16½ photo poster gives your store window interest... tells people a real reason for buying Sylvania Tubes.

HYGRADE SYLVANIA CORPORATION,
 SYLVANIA DIVISION, EMPORIUM, PENNA.

(K-9-1)

Please send me FREE the Political Poster shown above, together with the Sports Poster described in the box.

NAME _____

ADDRESS _____

CITY _____ STATE _____

I would also like to learn more about the Sylvania no-cost Analyzer Plan ; the no-cost Service Kit Plan .

ATWATER KENT RADIO



Model 812
12-tube highboy

\$139.50
COMPLETE



Model 188
8-tube lowboy

\$73.75
COMPLETE

*Never before
such features!*
FOR YOUR SALES

NOT JUST ONE or two big-time features—**BUT EVERY-**
THING your public is asking for!

That's the new 1933 Atwater Kent Winning Ticket Line.

Check this list, feature for feature, and try to think of any other radio that has them ALL or is built as soundly and scientifically as an Atwater Kent.

- ★ **FIRST AND ALWAYS—FULL-RANGE, SINGLE, LIFE-LIKE TONE.**
- ★ **★TONEBEAM**—"perfect aid to perfect tuning"—beam of light signals station at exact point of perfect tone.
- ★ **7 to 12 TUBES, INCLUDING 4 to 7 PENTODES.** All latest super-power types. Dual-grid radio frequency protodes. Mercury vapor rectifier. Double diode-triode—the 2-in-1 tube combining second detector, automatic volume control and first audio amplifier.
- ★ **B-AMPLIFICATION.** Increasing power more than 4 times.
- ★ **TWO SPEAKERS,** each receiving full 10 watts.
- ★ **ROOMY, FULL-ACOUSTIC SOUND CHAMBER;** no obstruction; all deep tones without booming.
- ★ **AUTOMATIC SILENT TUNING.**
- ★ **AUTOMATIC VOLUME CONTROL.**
- ★ **COMPENSATING QUICK-VISION DIAL.**
- ★ **RANGE SWITCH** for local or distance operation.
- ★ **5-GANG CONDENSER** in larger models; 4-gang even in Compacts.
- ★ **COMPLETE SHIELDING.**
- ★ **RIGID, DEEP-DRAWN STEEL BASE.**
- ★ **BROADCAST AND SHORT-WAVE RECEIVER** with single control switch, every tube in full, active use throughout entire range; freedom from spurious carrier signals. Critical short-wave fans hail this new 10-tube Atwater Kent as the champion, while as a standard broadcast receiver it is equal to the famous Model 469.
- ★ **NEW CABINET APPEAL.** Hanging from luxurious highboy with doors to dignity. Compacts. Figured walnut and hurl maple.
- ★ **COMPLETE LINE** for every taste and pocket-book—and no dudheads! A.C., D.C. and battery models, and Atwater Kent Motor Car radio.
- ★ **LOWEST PRICES IN HISTORY** for highest Atwater Kent quality.

The whole line is scientifically designed to get the best cooperation of tubes, speakers and roomy sound chamber—to give the owner the greatest power and the truest tone without trouble or complications . . .

AND BACK OF ALL—*the square, time-tested policy of Atwater Kent, with controlled production*

TONEBEAM LIGHTS

ATWATER KENT RADIO

*Never before
such a prize contest!*

FOR YOUR CUSTOMERS

1st Prize \$5,000

IN ADDITION to the 1933 all-star models, Atwater Kent announces a Word Game contest that will draw a vast number of radio-minded people to your stores to see the new radios and get entry blanks.

- | | |
|--------------------------|----------------------|
| \$5,000 first prize | \$250 fourth prize |
| \$1,000 second prize | 5 prizes, each \$100 |
| \$500 third prize | 15 prizes, each \$50 |
| AND 30 prizes, each \$25 | |



Model 260 \$99.75
10-tube semi-highboy COMPLETE



Model 469 \$89.75
9-tube lowboy COMPLETE

Enormous public interest in an easy, simple contest with alluring cash prizes is *another* reason for concentrating on Atwater Kent Radio this year!

For details of this, the soundest, most entertaining and most profitable contest of the year, see your Atwater Kent distributor and get entry blanks and broadside-poster. They have all the information for yourself and your community.

ONCE MORE: *An Atwater Kent for your customer is the best deal for you!*



Model 627 \$53.90
7-tube Compact COMPLETE
(also 8-tube Compact, \$63.90) COMPLETE

THE WAY!

From the Rockies west and in Canada prices are slightly higher

ATWATER KENT MANUFACTURING COMPANY A. Atwater Kent, President
4700 WISSAHICKON AVENUE, PHILADELPHIA, PA.

The

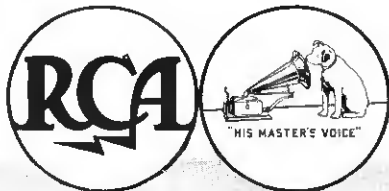

RCA Victor

Victor dog TALKS!

... and a new kind of hard-hitting advertising goes to work for RCA Victor dealers!

You'll find him in the Fall magazines. Meet him in the newspapers. You'll see him up on all fours—out of his trade-mark—talking straight from the shoulder to your trade.

The music trade's biggest business builder selling as only the world's most famous trade-mark can sell! There never has been any radio advertising like this.

This advertising says: "Here's something hot! Here's something so big it has brought me, the Victor dog, out of my trade-mark!"

Here's something you simply must hear!...

"Call on your RCA Victor dealer and hear it!"

We can talk that way — because our line backs up our promise! It has eye appeal—ear appeal—price appeal! It has feature after feature that spells V-A-L-U-E to the hardest-bit bargain hunter.

Bi-Acoustic Radio is the keystone—the Big News. But the whole line is a line you can honestly get behind and plug!

Don't expect the whole story here! Just look at these two sample numbers. Then call up your RCA Victor distributor. And let the Victor dog go to work for you—now!

The RCA Victor Co., Inc., Camden, N.J.

"RADIO HEADQUARTERS"

A Radio Corporation of America Subsidiary



RCA Victor Model R-76—Standard 10-tube RCA Victor super-heterodyne chassis. Plus "B" Amplification, which doubles watt output and eliminates overloading and speaker spill-over... Tone Equalizers, built-in compartments that eliminate "booming" frequencies... Automatic Volume Control, newly perfected and improved... Micro-Tone Control... New Type Radiotrons, giving greater gain with less current consumption. Cabinet of walnut veneer, wax-lacquer finish, open-face early American style. Suggested list price, complete... \$93.50



RCA Victor Model R-77—The same chassis as the R-76... 10 tubes, "B" Amplification, Automatic Volume Control, Micro-Tone Control, etc... in a handsome six-legged console with doors. Quilted maple veneer side panels and doors... fine molding and detail. Built to sell on side-by-side tone comparison test, with "B" Amplification and our New Automatic Volume Control, giving you an edge that swings sales. Plenty to talk about... plenty to show. Suggested list price, complete... \$104.50

Radio

Radios
Phonograph Combinations
Victor Records



**4 months
from now
you'll be glad
you read and
acted on this
advertisement**

It Isn't *how much*
you sell, that counts,
but how much money
you have made at the
end of the year

• **W**HEN you come to review your 1932 business and to consider where you're headed for '33 consider from where your profit—your **REAL** profit—has come.

In nine cases out of ten you'll find it's the item that has been made easy for you to sell without having to cut price, that is profitable.

Ohiohm Resistors — in the First-Aid Kit, in the Server for counter use, in the jobber cabinet — in every form — are highly profitable. And, we can prove it to you if you'll give us the chance.

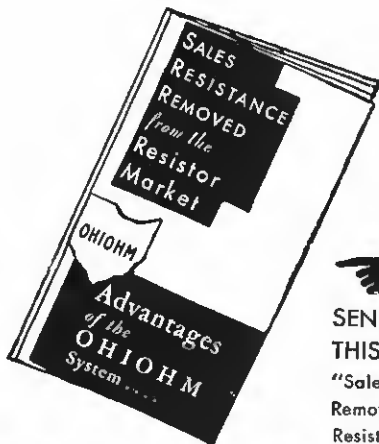

SEND FOR
THIS BOOKLET
"Sales Resistance
Removed from the
Resistor Market"

THE OHIO CARBON CO.

12508 BEREA ROAD :: CLEVELAND, OHIO

Ohiohm Resistors are made in Canada by
C. C. Meredith & Co., Ltd. :: 67 Bay St. Toronto

OHIOHM

Ohiohm Spark Suppressor Sets for
Eliminating Ignition Interference on



Radios
Installed in
Autos.

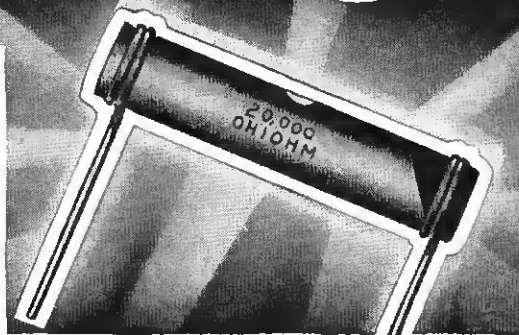

First Aid Kit for
Service Men.



Ohm Dial and
Service Labels
furnished Free with initial
order.

The Whole World Listens-in with ARCTURUS



Over 75 different nations attest the superiority of the BLUE Tube

In every territory of the United States and in 76 foreign countries you will find Arcturus *Blue Tubes*. Tried and proved by critical engineers here and abroad, the *blue* tube has achieved world-wide acceptance.

Blue Tubes are the product of the engineering experience that pioneered unitary structure, and practically every major advance in a. c. tubes. They are constructed with 'die-like' precision within the most rigid limits. Their perfection is guarded by 137 tests and checks.

For these reasons, it is readily understood why more set manufacturers use the *blue* tube as initial equipment than any other tube . . . why the people of more than 75 different countries use Arcturus Tubes . . . why more eminent radio engineers the world over specify Arcturus . . . why more dealers sell them.

Every industry has its symbol of excellence . . . in radio, it is *Blue* . . . Arcturus *Blue Tubes*.

ARCTURUS RADIO TUBE CO., NEWARK, N. J.



Any SET IS BETTER
with BLUE ARCTURUS

ARCTURUS

"The BLUE TUBE with the LIFE-LIKE TONE"

DIRECT from REPLACEMENT PARTS HEADQUARTERS

Two Catalogs You Should Have

Both contain information that you can turn into dollars—both describe parts that will bring you more business and give your customers greater satisfaction. Mallory leadership is the result of Mallory

pioneering—Mallory pioneering is tangibly reflected in terms of profit for every retailer and service man who wants his place of business recognized as replacement parts headquarters for his community!

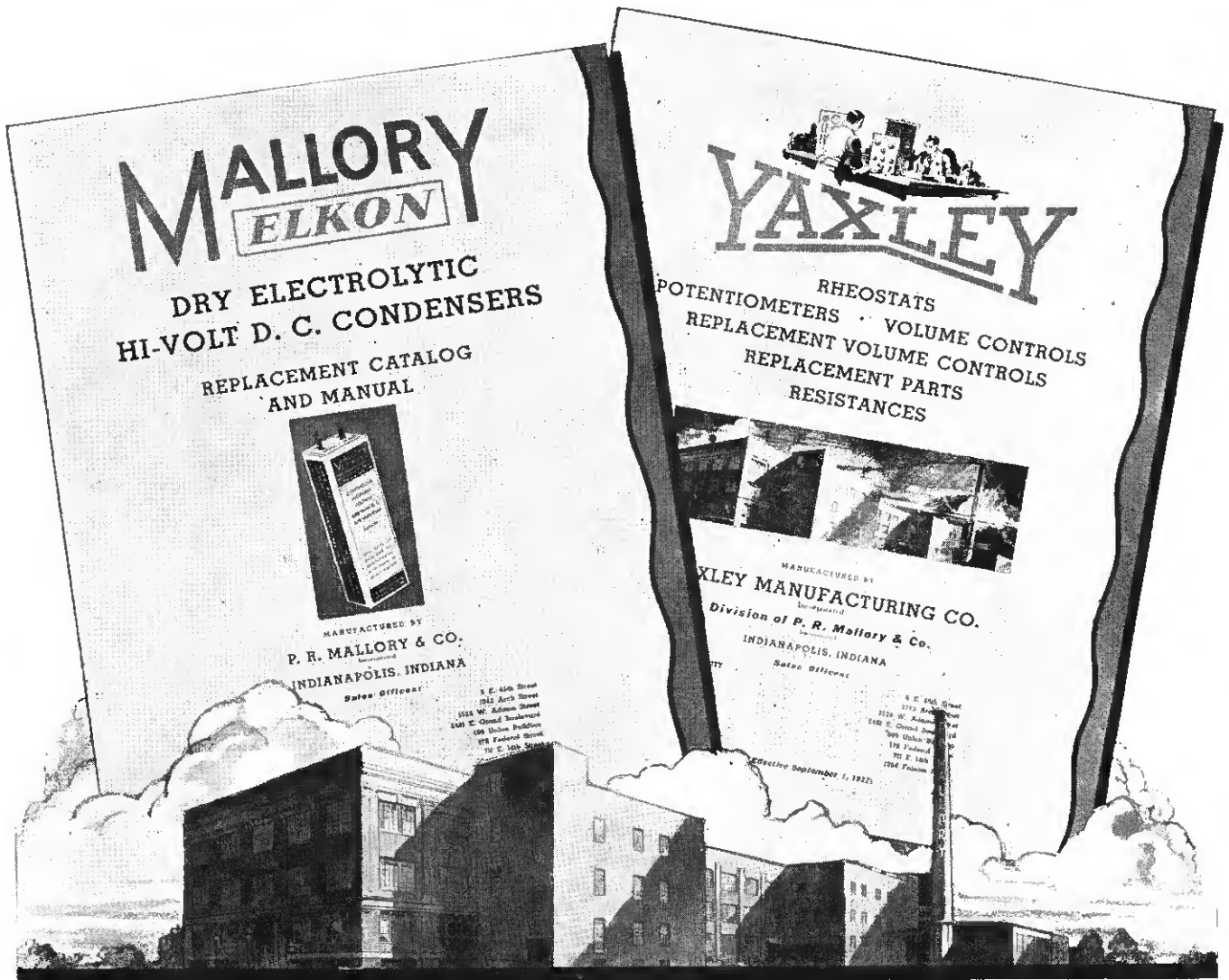

Mallory-Elkon condensers assure the user of characteristics and performance never before obtainable. Yaxley Volume Controls, Rheostats and Potentiometers are attracting nation-wide attention. Two great groups of radio engineers are responsible for these outstanding contributions to the radio industry. Write for both catalogs today—each contains a complete replacement chart listing the proper product for each set.

Service Men The Country Over Use These Yaxley Replacement Parts

Volume Controls, Rheostats, Potentiometers, Short and Long Wave Switches, Radio Convenience Outlets, Resistances, Jack Switches, Push Button Switches, Tip Jacks, Phone Plugs.

And don't forget to write for full details covering the Mallory-Elkon "B" Eliminator that has made auto radio all-electric.

P. R. MALLORY & CO., Incorporated, INDIANAPOLIS, INDIANA

Cash in On the ONLY Radio Selling Scoop of the Year—the



4 DIALS IN ONE THAT COMMANDS ALL THE WORLD

STEWART-WARNER

A YEAR AHEAD WITH PROVED 'Round-the-World' RADIO, AGAIN LEADS THE FIELD WITH THE ONE BIG SELLING SENSATION OF 1932-33—THE *Magic Dial*, THAT OPENS UP NEW AVENUES OF *World Wide Reception*.



Master All-Wave Console

11-tube, duo-superc heterodyne circuit—*Magic Dial*, Automatic Tone and Volume Control—with Stewart-Warner new type Electro-dynamic speaker. Console of modified 18th Century design. Genuine wood-carved front of matched Burr Walnut with flanking curved pilasters. Grain walnut sides. 45 1/2 inches high, 26 1/2 inches wide, 16 inches deep—complete to retail at \$159.50.

A complete line of 11 models, including a separate short wave converter—prices from \$20.95 to \$194.50.

To profit this year, the radio dealers must have a big, new, vital selling feature—they must offer the public a real reason for buying.

Stewart-Warner dealers alone can offer such a feature—the *Magic Dial*—mysterious, awe-inspiring, gripping—the sensational development that makes all other radios out of date. For the *Magic Dial* brings within easy reach the new thrills of the ether waves—introduced to the public last year by Stewart-Warner's 'Round-the-World' Radio.

Backed by masterful, interest-exciting, national advertising—with startling, magnetic new window displays spotlighting the *Magic Dial*—Stewart-Warner dealers have a selling opportunity unequalled in Radio history.

But the Stewart-Warner franchise will give you more than that. It gives you a complete selling set-up—that enables

you or your salesmen to turn into sales, the prospects who come in to "hear what the *Magic Dial* does"—"to see how it works."

Get the facts from your nearest Stewart-Warner Distributor or use coupon.

Stewart-Warner Corporation
1826 Diversey Parkway, Chicago

BU-0

Please send me full information on your *Magic Dial* Radio line.

Name _____

Address _____

City _____ State _____

STEWART-WARNER RADIO

OVER 30 MILLION SATISFIED OWNERS OF STEWART-WARNER PRODUCTS

...The New Seven

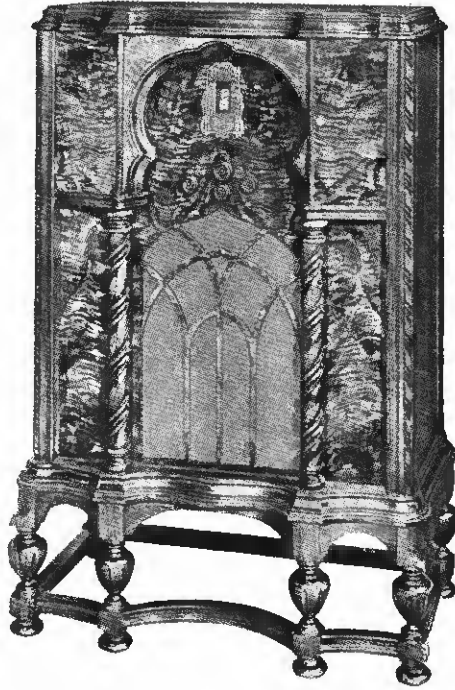
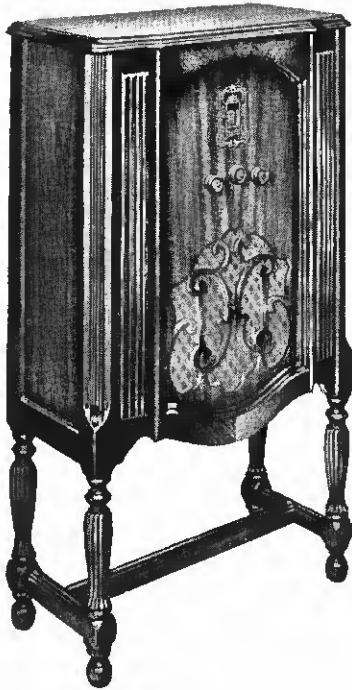

Model 220 . . . The lowest price in history for a Zenith console . . . Only \$62.50 (Complete with Zenith quality tubes . . . tax paid)

Model 245 . . . Lowest price ever for Zenith Automatic Tuning . . . Only \$102.50 (Complete with Zenith quality tubes . . . tax paid)

Model 430 . . . Never before have you been offered a radio equal to this new Zenith . . . Only \$166 (With Zenith quality tubes . . . tax paid)

14 NEW MODELS . . . \$49.95 TO \$184 COMPLETE—TAX PAID

A CHALLENGE

"We challenge anyone to name a single demonstrable improvement in radio which is not found in the new Zenith 1933 line and we further challenge anyone to name a radio line which contains all the improvements found in the new Zenith 1933 line."



Prong No. 59 Tube

... ANOTHER SCOOP FOR ZENITH

A GAIN Zenith adds a major development — making 38 contributions to radio progress. Again Zenith distributors and dealers lead all the rest.

New 1933 Zeniths employ the latest development in power tubes ... the No. 59 with 7 prongs. A Cathode type, it combines the advantages of all former filament type of power tubes with none of their disadvantages. It also combines the advantages of both the "A" and "B" type of amplifi-

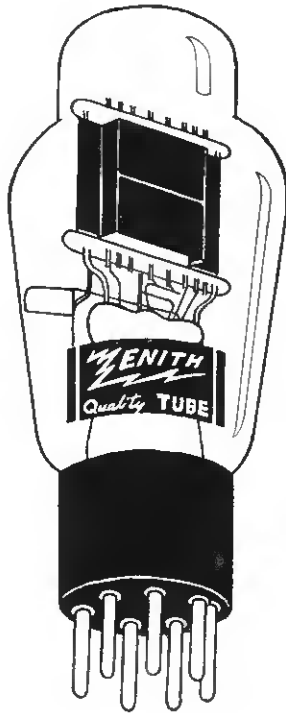

cation in this new great "AAA" circuit. It gives great power without distortion even at lower volume. It eliminates hum.

Any radio that doesn't use this new tube is out of date. Watch others adopt this wonderful improvement as soon as they can change their circuits.

This is only one feature in the first ALL-STAR Radio Line. Watch the coming announcements for other Zenith features. Better get in touch with your distributor now.

ZENITH

TRADE MARK REG

RADIO

THE ALL-STAR ZENITH LINE

- ★ No. 59 seven-prong power tubes
- ★ Automatic tuning
- ★ Automatic catenary tone-volume compensation
- ★ Four-light automobile dash-type escutcheon
- ★ Hi-Lo multiple speakers
- ★ Shadowgraph tuning
- ★ Visual tone control
- ★ Visual volume control
- ★ Full circle logging dial
- ★ Police Calls and new 540 K. C. Canadian Station
- ★ Between-station noise suppressor
- ★ Short, standard, and long wave receivers
- ★ Dominant beauty in cabinets
- ★ Liberal selling plan



Radio Dealers everywhere realize the tremendous sales possibilities offered to them by owners of 32-volt Farm Light Plants and the L. Tatro 32-Volt Farm Radio, whose brilliant, rich, mellow tone and super-performance have won and earned for it the reputation of America's Favorite Farm Radio.

This great Radio pioneered the All-Electric Farm Light Plant Radio—today it is still the leader in its field maintaining its nationwide popularity by a comprehensive national farm advertising campaign. You can easily cultivate this rich sales field—it will prove highly profitable for you.

We have a wonderful proposition for jobbers and dealers—one of the real money-making Radio opportunities of the year. Wire or write today for complete facts.

**L. TATRO PRODUCTS
CORPORATION**
Decorah • Iowa



L. TATRO 32 VOLT SUPERHETERODYNE

●
• **FOR FARM
LIGHT PLANTS**
●



ALL ELECTRIC
No Batteries

MULTI-TUBE
All Latest Tubes

**DUO-DIODE
DETECTION**
Unsurpassed Tone

**AUTOMATIC VOLUME
CONTROL**
No Fading

A formula for Faster Turnover

HERE'S a formula for faster turnover that gets results: Display the merchandise advertised in **THE AMERICAN WEEKLY**.

Manufacturers advertise their products in this mighty magazine principally because it has the world's greatest circulation.

Reaching over 5,500,000 families every week, its power is so far-reaching that it actually influences the buying habits of one out of every five families in the United States.

Display the merchandise advertised in **THE AMERICAN WEEKLY**. Make its readers your customers, and prove for yourself that here is a reliable formula for faster turnover.

What is The American Weekly?

The American Weekly is the largest magazine in the world. It is distributed through 17 great Sunday Newspapers. In 558 of America's 995 towns and cities of 10,000 population and over, The American Weekly concentrates 70% of its circulation.

In each of 136 cities, it reaches one out of every two families

In 105 more cities, 40% to 50% of the families

In an additional 153 cities, 30% to 40%

In another 164 cities, 20% to 30%

. . . and, in addition, more than 1,750,000 families in thousands of other communities, large and small, regularly buy and read The American Weekly.

THE AMERICAN
*Greatest
Circulation
in the World* **AWEEKLY**

"The National Magazine with Local Influence"

Main Office: 959 Eighth Avenue, New York City

*Branch Offices: PALMOLIVE BLDG., CHICAGO . . . 5 WINTHROP SQUARE, BOSTON . . . 753 BONNIE BRAE, LOS ANGELES . . . 222 MONADNOCK BLDG., SAN FRANCISCO
11-250 GENERAL MOTORS BLDG., DETROIT . . . 1138 HANNA BLDG., CLEVELAND . . . 101 MARIETTA ST., ATLANTA . . . INTERNATIONAL BLDG., ST. LOUIS*



The Mark of RADIO'S GREATEST VALUES

★ Automatic
Silent Tuning . . .

★ Class B
Amplification . . .

★ 4-Indicator
Illuminated Uni-Dial

★ New Triple
Grid Tubes

★ Mercury Vapor
Rectifier

★ Matched
Dual Speakers

★ Distinctive New
Cabinet Designs . . .

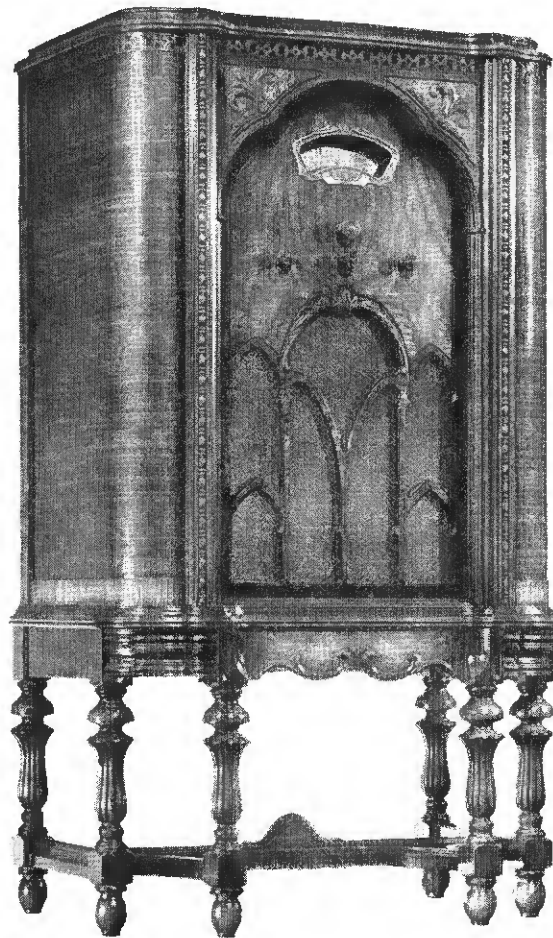

U. S. RADIO, Apex Model 12B, illustrated, is standard-bearer of the 1932-33 U. S. line of 8 new models. Check every feature . . . compare . . . and you'll know why it is the biggest dollar value in Radio today! Complete, with 12 tubes **\$107.50**

● *AGAIN*, in the 1932-33 models, U. S. Radio has embodied every significant advance in radio engineering . . . features which challenge the interest of the public, and command profitable business for the dealer.

Once more, in its complete new line, U. S. Radio affords striking proof of that leadership in value-giving upon which U. S. Distributors and Dealers have built sound and increasingly profitable business—values which have made U. S. one of the world's largest manufacturers of radios.

To make the most of merchandising opportunities in the present season you need the greatly improved reception qualities, the vastly bigger dollar values, embodied in the U. S. line. Write or wire now for all details.

● UNITED STATES RADIO & TELEVISION CORPORATION
MARION, INDIANA

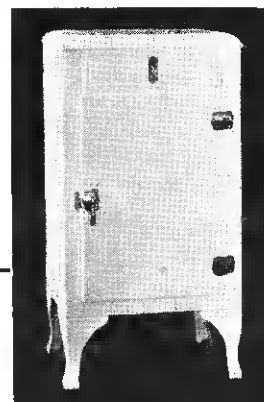

U. S. HERMETIC Refrigerator **\$99.95**
f. o. b. factory

The FIRST hermetically sealed refrigerator in a price range starting under \$100—setting a new standard of values. Available in three sizes—five models—and covered by three-year guarantee.

RADIO RETAILING

HOME ENTERTAINMENT MERCHANDISING

O. H. CALDWELL, *Editor*

RAY V. SUTLIFFE, *Managing Editor*
W. W. MACDONALD, *Technical Editor*
T. H. PURINTON, *Assistant Editor*

M. E. HERRING, *Publishing Director*
HARRY PHILLIPS, *Art Director*
P. WOOTON, *Washington*

On a *Silver Platter*—

I HAVE just come from the studios of the great broadcasting systems. They are all "steamed up" and busy as bee-hives with big plans for program features this Fall and Winter. They are spending money for talent and novelties at a rate of prodigality to make Ziegfeld turn over in his untimely grave. And all this parade of million-dollar programs, news features, music and education will help radio dealers sell sets this Fall!

I have just bumped into some of my Washington friends who are now in the thick of politics. Never, they tell me, was so much interest manifested in an election. This Fall, they say, people will be sitting close to their receivers, carefully taking in every word. Never was an election held that meant so much, personally, to so many people. Radio will be the battleground for ballots. News will be in demand early and late, every night this Fall. And here again the radio dealer wins!

I HAVE talked with the radio-set manufacturers. They have new models that are wonders,—with new depths of beauty of tone, new appeals for purchasers to bring out hoarded dollars. The manufacturers have given the dealers fine merchandise to sell, and at prices that must move the goods.

Nowhere else is any group of merchants blessed with such an opportunity as is now laid at the feet of the radio dealers of America in this Fall of 1932. Programs, concerts, stage stars, news events, politics, the campaigns, the elections, improved merchandise,—all combine to make radio the most important item in any home.

We have all been through some tough times together, these past two years. But now it looks as if the gods of politics and the gods of broadcasting had contrived to hand us opportunity galore—hand it to us on *silver platters*. Radio's "big push" is on!

O. H. Caldwell

EDITOR

“I
demonstrate
the

DIFFERENCE”

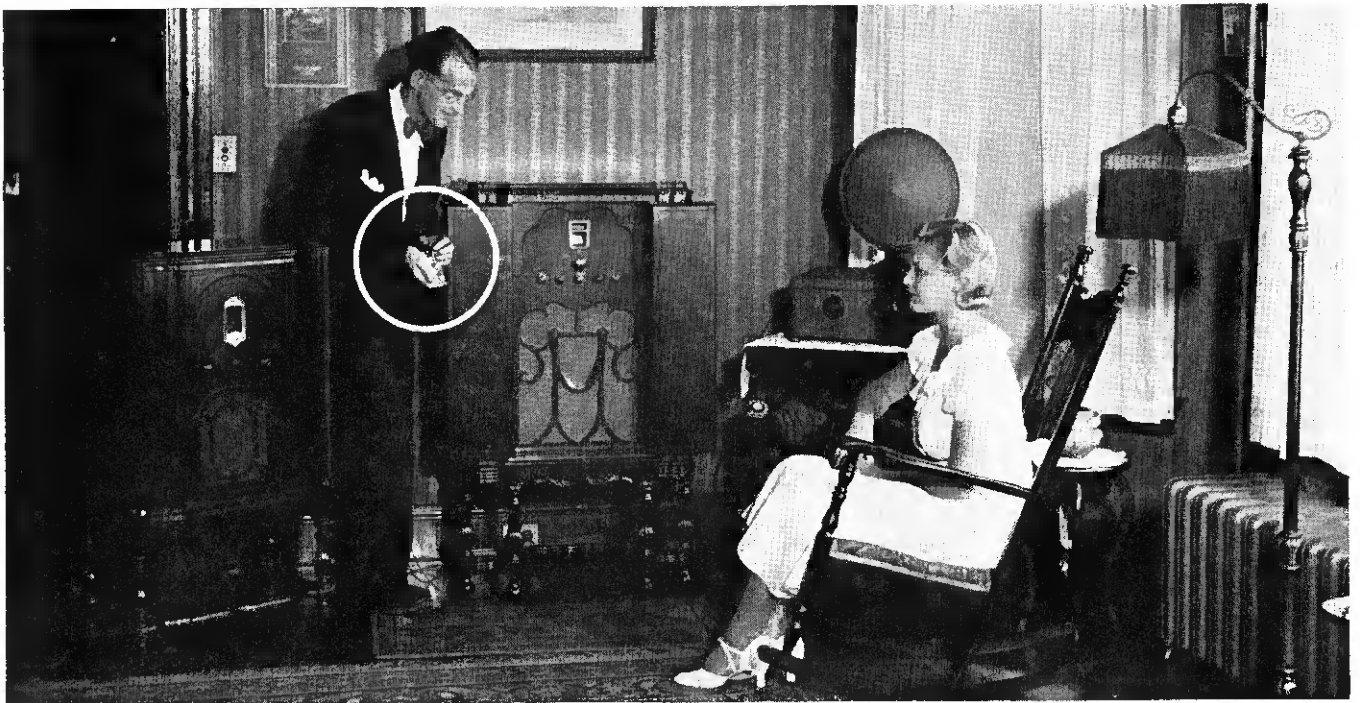
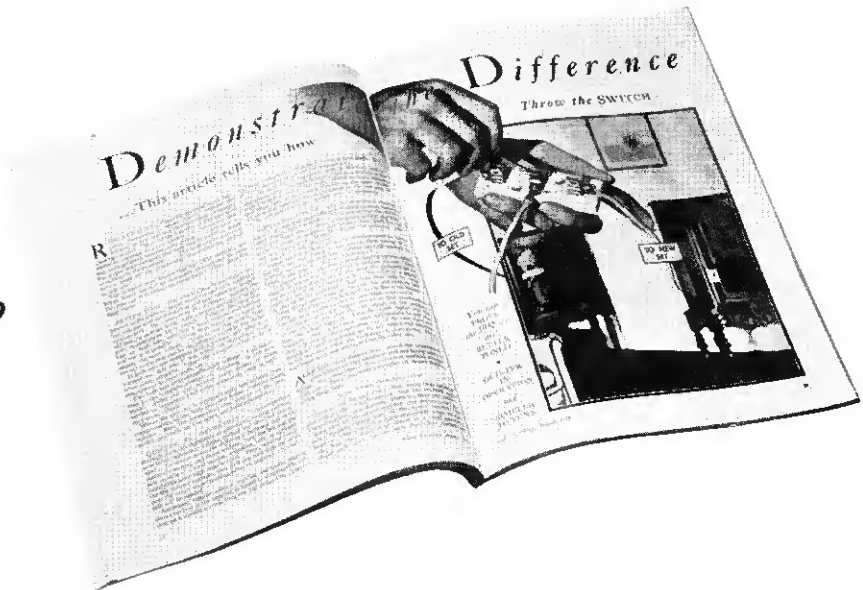

LAST month's issue of your magazine featured an idea for building fall and winter sales: "Demonstrate the Difference." It's an excellent suggestion and it ought to click. How do I know? I'm doing it . . . And it works!

The 1932-33 sets certainly are far better than those of last year; "demonstrably so" as you said in your August article—and that's the way to sell them. Our present market must run at least 80 per cent replacement business (my percentage is nearer 90). And to "displace" an old set means getting right into that front

parlor with a new outfit and giving the old one the works. Show it up, in one, two, three order, in other words. I'll go further than that: get into that living room with *two* new sets—a popular-priced one and a high-quality model. If demonstrating one set is a good idea, two is still better. That's been my experience anyway and directly I'll give the reasons why this is a good idea.

But before you can pull that trick demonstration that *Radio Retailing* recommends, you first must catch your prospect. And right here, Mr. Editor, is where I differ

This
Hartford, Conn.,
Dealer
finds that
Radio Retailing's
plan for getting
business this fall
WORKS



... says R. G. Sceli

with you. It was a mighty good article—sound theory—but you shouldn't stand for indiscriminate demonstrations, free of charge. That's where you're dead wrong. I bait my hook with red meat—have for three years—and they like it. By this I mean that I charge one dollar for every home demonstration I make. If the deal is closed, and in four cases out of five it is, the buck applies on the down payment. But if the set comes back the dollar stays with me.

I think it's good salesmanship to do this—call it psychology if you must. Anything a man has to pay for he always values. Furthermore that slight charge helps cover the added expense of giving the prospect his choice of hearing two sets in his own home. Lastly, we stage a real show—worth the price of admission. We give a "planned" sales talk and demonstration. Try to do the right thing at the right time, make quick change-overs from the old to the new set, and from one new set to the other.

But I'm getting ahead of my story. Because, before the dollar charge, you must find out who might consider buying a new set. I get my leads mostly from my consistent newspaper advertising. I run a small, one-column ad every day. Once a week I take two columns and feature the "\$1 Delivers a Radio" idea. This ad is generally good for at least one direct sale. Note that while one dollar will assure delivery of a set to a person's home, for demonstration purposes only, I insist on ten per cent, or more, down before leaving it there permanently. Even in these times I encounter very little resistance to this policy—and they accept our explanation of just what the "Dollar down delivers" means with good grace—it's all in the way you put these things—salesmanship.

Six per cent of my total gross goes for advertising. It's necessary and it's worth while. My business, in unit sales, is ahead of last year's—which totaled, in money value, \$66,500.

NOW for the actual, comparative demonstration. While the prospect is in the store we get him to make a tentative selection on the basis of cabinet design, price and make. If no one model captures his imagination we narrow the field down to the *two* he likes best. We also find out what member of the family does the actual spending and arrange to deliver the sets for demonstration when both the buyer and anyone having the power to veto can be present. We avoid demonstrating on evenings when the neighbors are going to be invited in.

Right after the supper dishes have been put away, about eight o'clock, is a good time to start the demonstration. Myself, or my salesman, arrives half an hour earlier, to check the antenna, ground and local reception conditions. We then hook the old set and the *best* new one to the antenna through a double-throw switch. The salesman starts the demonstration, after the stage is properly set and the prospects comfortably seated, by featuring what, to my mind, is the most tangible difference between the old set and the new—automatic volume control plus automatic muting. These spectacular points make an instant and profound impression and relatively few people know about them.

"I will first show you the 'free wheeling' of the *new* radio sets," the demonstrator says. The new set and the old one are then turned on, with the antenna switch open while the tubes heat up. Then the antenna is connected to the old set and the salesman tunes in a fairly weak signal. *It is not a good idea to let the prospect tune the old set at this point as this introduces a dangerous spirit of competition.*

The volume of the old set is adjusted to the level the prospect likes best and then, standing beside the set and not in front of it where he would hide the dials, my man tunes slowly across the scale without touching the

volume control. As the set is tuned to a weak signal the gain is high and so not only do electrical noises and static come in loudly between stations but strong locals burst suddenly upon the scene with a crash. (This is better than starting with a loud local, as recommended in your August article).

When this has been done the set is shut off and the prospect's attention called to the annoyance of noise between stations and also blasting by locals. Now the new set is connected, tuned to the same station and to the same volume. Again standing to one side of the dials our man puts it through identically the same paces. This cannot fail to make an impression as not only do all stations come in at about the same volume but the set is as silent as a tomb in between.

If the prospect evinces interest in tuning the set himself at this point he may be permitted to with perfect safety. He will, without question, be struck by the ease of tuning, especially if the set has a tuning meter which eliminates fishing for the center of the signal in order to get good quality.

NEW FEATURES ARE IMPRESSIVE

ONCE the prospect is intrigued by the tuning of the new set he is prejudiced in favor of it. Now is the time to swing to tone quality. This factor is not quite so tangible to demonstrate but the sale has been given impetus by the flashiness of automatic volume control, automatic muting and meter tuning. In other words, we go into the tone act with a flying start.

We begin about like this: "Now I want to show you how much more natural music and speech sound on this new set. It is easy enough to make a receiver which reproduces the low notes, or gets the highs only, but something else again to make a set that brings in *both* exactly as broadcast. Frankly, your old set really is pitched higher (or lower) than natural."

Then, selecting a symphony orchestra, (avoid vocal and instrumental solos and dance orchestras wherever possible) the salesman tunes in the old receiver to the best of his ability. If the prospect thinks he can do a better job he is permitted to try. Then my man proceeds to pick the reception apart, carefully, however, in order not to appear biased. He "pans" the old set, tactfully, all the time it is playing. If possible he catches an announcement, to point out the slurring of sibilant or "s" sounds, explaining that this is a sure sign of faulty

reception. Then a *quick* switch is made to the new set, on the same program. The salesman first remarking: "Now I'll let my set talk for itself." He then leans back and relaxes, endeavoring to induce this same feeling in his prospects. Satisfied silence is the keynote at this point. Reason—make it hard for them to listen to their old set and easy to listen to your new one.

Frequently the demonstration can be concluded right here, and the talk switched to dollars and cents. If so, the salesman asks whether the prospect prefers classical music or jazz, gets a good station and then turns the volume down low. There is no cut and dried formula for closing, as we all know, but I think the *very soft* musical background helps. Here's my theory: if the set is turned off completely the abrupt silence puts the prospect on guard, warns that the more disagreeable selling operation is about to take place. On the other hand a background of soft music relaxes everyone and permits a casual introduction of the "which set may I leave, Mrs. Brown?" theme.

Of course demonstrations must be kept flexible. If our salesman feels that his prospects are less impressed by the difference in tone quality than by the modern tuning conveniences he quickly concentrates on the latter, cutting his tone demonstration short. In such cases, where the set is equipped with the shortwave feature he sometimes succeeds in closing by picking up police reports and 80 meter amateur phone conversations. Foreign reception is usually avoided by claiming that the stations are not on, as such dx we have found, is rarely available "on order."

HAVE you been wondering what has happened to the second new set all this time? We do not demonstrate it as long as there is a chance of selling the better and higher priced one. Not until the prospect requests it, which, of course, happens sooner or later, do we make the new models compete with each other. First, we must 'show up' the customer's present set. Many times two new sets will do this more effectively than one. Sheer weight on numbers.

After the customer's set has clearly been "outpointed" then the more delicate matter of which new set to buy may be opened up.

Yes, I like the two-new-set idea. We invariably (four out of five demonstrations, Ed.) sell one of them—generally the higher priced outfit.

About That Switch

In order to best "demonstrate the difference" between an old and a new set, *Radio Retailing* has recommended the use of a switch to make instantaneous comparison possible. Now Jack Schiefer, of the Electric Construction Company, Fresno, California, writes that he is using the idea to advantage and has devised a switching system that does a bang-up job.

"Many of the new sets are so sensitive that they continue to play on the short length of wire between switch and antenna post even when the antenna itself is connected to the old set—unless some special precaution is taken to mute them," he advises. "This

is best done by using a double-pole, double-throw switch in conjunction with a shielded single-conductor. The latter preferably should be of the copper-braid variety.

"Connect up the switch as shown in the accompanying drawing, using the shielding of the conductor as the ground lead to both sets while the inner conductor serves as the antenna lead. It will be seen, upon examination of the simple circuit, that when the antenna is thrown to one receiver the antenna circuit of the other is shorted to ground, effectively eliminating pick-up. An ordinary porcelain-base switch may be used if a piece of felt is glued to the bottom to protect furniture.

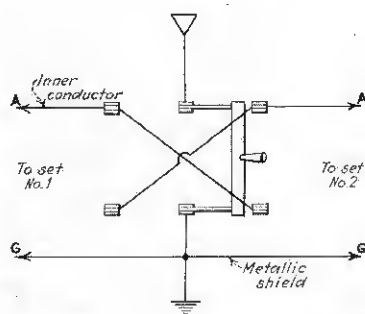

ACTION!

On-the-Spot
BROADCASTS
will mean
On-the-Job
LISTENERS



"HEAVENS, 'TIS MY HUSBAND!"

Broadcast actors will now emote on the actual spot where the crime was committed—and the listener receive an extra quota of thrills



RKO Radio Pictures personalities who may broadcast this winter: 1. Richard Dix, 2. Constance Bennett, 3. An Harding, 4. Irene Dunne, 5. Helen Twelvetrees, 6. Joel McCrea

A BROADCAST from a barrel bouncing over the brink of Niagara . . . Drama from Broadway stages, with tiny microphones concealed in the costumes of the cast . . . Debates from congressional halls or testimony of witnesses in court . . . Travelogues at the source, —from explorers deep in the jungle or far out on the ice packs . . .

Such features may comprise the radio events of the near future as the result of current experiments with the lapel microphone by the Columbia System. This marvelous device will give radio rover-mobility. It will open numerous broadcasting opportunities where compactness, light weight and even concealment might be necessary. It will permit the remote broadcast crew to cover occasions that require silent operations, speed and agility. In brief, the small mike should be the boon to broadcasting that the portable motion picture camera is to exploration and the photoflash bulb to news photography.

ONE of NBC's outstanding contributions to the new broadcasting era is the making available to the radio listener the talent of Hollywood's leading motion picture actors and actresses. This policy and its significance was reported in the news items of last month's issue of this magazine. Needless to say the "air" presence of screen stars in unique "action" programs, at the same time that their latest picture success is being shown throughout the land, will rate high among the many reasons why the set owner will find, in this winter's programs, an irresistible appeal.

THEN, too, there is the new "velocity" microphone, produced by RCA-Victor, which uses a sensitive ribbon instead of the usual diaphragm. Because of its radically new principle the use of this mike dispenses with much of the cumbersome studio paraphernalia which has heretofore cramped the style of performing stars, retarded their free action.

The new instrument has positive directional characteristics, being highly sensitive on two sides while almost completely non-responsive on the others. Performers need no longer crowd unnaturally to one side of the mike but may speak their lines, with greater freedom of movement, from opposite sides.

A PLAN for

Reorganization of this Association Creates

ON AUGUST 23rd, the membership of the Radio Manufacturers Association ratified the re-organization plans for that body and RMA passed under the active control of the leading radio set executives. The principal set manufacturing interests are now represented on the board of directors and all are pulling together for the good of the radio industry.

Thus the machinery is provided for active industry cooperation. The tracks are laid for aggressive action, both to cure the internal ills of the industry and to promote radio sales to new levels. Fortunately this basic change in the RMA set-up comes at the opening of a season when radio is being given another unique opportunity for public interest and public service—through the Presidential election. For, as pointed out by the forceful new president of RMA, Fred Williams, *the radio industry is the only branch of all business which can benefit directly from the feverish activity of the fall campaign now beginning.*

Many proposals have been made for the future program of the RMA. It is generally recognized that the steps accomplished so far are but preliminaries to the real usefulness of the body in aiding radio. The active leaders in the RMA reorganization, however, have been loath to express their own views as to the future course of action for the association, feeling that such suggestions and proposals might best come out of the membership and out of the industry itself, after the preliminary internal changes had been completed.

Radio Retailing Presents a Program

BASED upon *Radio Retailing's* own wide contacts with the radio industry in all branches, dating from the very beginnings of public broadcasting, and drawing upon its own observations of the ills and needs of the radio business, the editors have prepared a list of opportunities for industry usefulness now before the RMA. On these pages we have itemized activities which this magazine suggests be at once undertaken by the reorganized body and its various groups, in order to speed the recovery of radio selling all along the line—from manufacturer to distributor to dealer.

Cooperative work in the various directions listed

will stimulate recovery throughout the radio industry. At the same time such action will constitute a real contribution to the public's greater enjoyment and use of the marvelous facilities which it knows under the term of "radio broadcasting."



Rebuild Popular Interest in Radio

Lay cooperative plans to reawaken the popular appeal of radio to present radio set owners, and particularly to reach the 15,000,000 American homes which are still without adequate radio.

Cooperation with Broadcasters

At the present time, the broadcasters operate wholly without consideration of the set makers, while the men who build and sell radio sets carry on their business without regard to the broadcasting service which is the very lifeblood of radio. Each group can aid the other with its particular problems. And working together, a stronger, more prosperous situation can be created for all.

A "National Board of Strategy" for Radio

Growing out of the preceding situations, there is need for setting up a National Board of Strategy for radio, whose limited membership of five to nine, will include representatives of the set makers, radio trade, broadcasters and national chains. Such a top steering body is badly needed to coordinate, into mutually helpful channels, the activities of the broadcasters and radio set industry.

Newspaper Advertising

Carry cooperative advertising designed to reach present non-listeners, pointing out the important features on the air, the notable foreign re-broadcasts, radio in the Presidential campaign, etc. Provide small boxes as above to be included in individual ads of radio manufacturers, distributors and dealers.

"Rejuvenate Radio Reception"

Take measures, through newspapers, broadcasts, dealers' window displays, etc., to show listeners how to im-

the RMA

Opportunity for Revitalizing Industry

prove their present radio reception and to eliminate interference that prevents the fullest enjoyment of radio.

Standards of Tone Quality for Radio Sets

Set up definitions of the lower limits of tone fidelity and selectivity which should be expected of a modern radio receiver. Encourage independent testing organizations to rate receivers by these standards and to publish results, in the same way that automobiles are rated.

"Modernize Home Radio"

Show the public why the radio set of a few years ago is now obsolete and deficient in tone quality, selectivity and sensitivity. Encourage the householder to buy a modern new set and keep his old set for the kitchen, or "upstairs." Make it a mark of modern home convenience to have *two or three radio sets*, in the same way that the number of baths in a house is an index of social standing!

Compile Statistics; Safeguard Against Overproduction

Make an annual accurate survey of production of sets, tubes, etc. Compile these figures for industry study, as a guard against over-production, dumping, and disaster.

Study Production Costs, Freight Rates

Lack of full understanding of the elements that go into the cost of producing sets and of shipping sets to distant points have been the source of grievous industry quarrels, wrangles and embitterments. Put these causes of trade troubles on a scientific basis, and solutions will readily present themselves.

Watch Legislation; International Relations

A united industry is needed to go to Washington and protect the interests of radio when either the broadcasting channels or radio-industry matters are assailed. The broadcasters problems of wavelengths and international assignments are in the end the problems of radio manufacturers and dealers. Conversely the broadcasters can exert powerful influence for the benefit of the radio-set industry.

Control Models; New Tubes

The whole question of when to bring out new models and introduce new tube types can be constructively handled in a way to benefit both industry and public.

Window Posters and Window Displays

Make available attractive instructive window placards and display material which can be used in the show-windows of radio's 23,000 retail dealers to interest the public in coming events on the air.

Police Destructive Advertising

Cooperate with the various Better Business Bureaus in "showing up" and putting a stop to destructive and misleading radio set advertising campaigns, which delude the public as to real radio set values.



MANY other activities for the new group will be suggested as time goes on. There are still many internal problems in radio manufacturing which will need to be worked out by the manufacturers themselves, and are, of course, their own private concern. These intra-manufacturing questions have not been touched on here, except as they relate to other branches of the industry.

But the above points, we believe, do constitute situations which have bearings on all groups in the radio industry and which have long awaited attention and solution.

May the re-born RMA find the strength and energy to go ahead and work out the answers to the many problems which still beset this industry that builds and sells "*the world's most marvelous merchandise.*"

Radio Retailing Proposes

A NATIONAL BOARD of STRATEGY

**to head the many activities for
promoting radio prosperity, now
before the reorganized RMA**

Meiklejohn's

THEY waste no time following prospects, keeping records or making daily written reports; they have no exclusive territories, they receive no salaries—yet Meiklejohn's free lance, tradition smashing salesmen get a good living, summer and winter, selling radio. The basic thought, in other words, of the Meiklejohn Company, Providence, R. I., in operating its outside selling crews, is CALLS—and then, *more calls*. Freedom from details, from backtracking on leads—and the devoting of the time thus gained to first-time contacts and on-the-spot closing, is the big idea. Naturally, if a second call will mean a sale the salesman makes it. But, unless the prospect absolutely means business, the representative leaves printed matter and his card and then tries the next house.

"We maintain no prospect lists," states Maurice Feingold, crew manager. "Many outside selling activities fall down because the salesmen waste so much time following worthless 'prospects.' I am interested in *today's* business. The value of the average prospect is deceiving—unless he or she makes a definite buying gesture. The contact has been made, the prospect has the firm's name and telephone number, and that of the salesman. If any further genuine interest develops the sale will not be lost. This has been proved many times since we launched this plan. Aside from the increased sales resulting from this policy we have received many favorable comments from the public to the effect that our men do not weary the customer with continued calls."

John Meiklejohn sums it up this way: "In the long run the salesman will book more business by exposing himself to as many different people as possible rather than by spending fifty per cent of his time recultivating lukewarm prospects."

Now the follow-up plan—the "never let go while hope remains"—philosophy has been accepted as the first commandment of field selling since doorbells were

Orthodox Philosophy—

"Never let go while hope remains!"

Meiklejohn's Philosophy—

"Forget 'em unless they're 'live'!"



invented. In most cases, particularly in smaller places, this has been wise. Let us see, therefore, how the opposite policy can be made to function; how Meiklejohn utilizes the good from both systems.

Control, Through the Five O'Clock Meeting

HOW, it at once will be asked, can control of manpower be exercised under such a loose set-up? Will the sales representatives stick on the job and work? Won't they swipe each other's choice prospects?

The composite answer to these questions is supervision—in the field and at the daily five o'clock meeting. The management pitches in and works closely with each member of the staff.

Crew manager Feingold and general sales manager John Meiklejohn go out with their men. They devote hours to personal training—in the field. The latter assigns sales quotas, runs monthly contests, and awards \$25 and \$50 bonuses. But the keystone of Mr. Meiklejohn's plan is the five-p.m. get-together.

"At these meetings," he states, "the problems of the day are frankly stated and freely discussed. If conflicts occur between the men, they are ironed out. Sales records are reviewed, new product developments studied and the spirit of the discouraged revived."

The Meiklejohn Company started its intensive outside selling drive on radios the fore part of 1931. At the height of its activities it had 45 men in the field, operating from three stores, Providence, Pawtucket and Woonsocket. Today its force numbers thirty. With but few exceptions the original crew is still on the job. Last year these men averaged \$102 per set sale. This year, due to well-known conditions, the average selling price will be about \$60. However, the men like the freedom and the many sales opportunities which

MEN . . . they waste no time on

lukewarm prospects



. . . maintain no follow-up lists

. . . write out no sales reports

the "Meiklejohn plan" affords and all have declared that they will stick it out. They sell some phonographs, carry a selected list of records and are trained to talk refrigeration also. But the surprising thing to date is that radio sales have constituted over 70 per cent of their dollar volume, this summer as well as last winter.

Perhaps the statement of one of these salesmen will help explain the success of this well-known Rhode Island house with its outside venture. He says:

"About a year ago, when the firm launched its intensive field work, I started working for them as a member of the field gang. The very fact that I'm still with them and perfectly satisfied with my earnings proves that radios and related lines of merchandise can be sold outside.

"My procedure is to lay out a course for myself, going from door-to-door, contacting the housewife or head of the home. A short sales talk, the use of the Meiklejohn name, literature which identifies me as an authorized salesman and the leaving of a business card constitute my main sales efforts.

"It is a surprising fact that sales can be made without any previous lead, without any previous sales work. There are at this very minute many persons in Rhode Island who would purchase a radio if approached—and that's just what we're doing."

In his concluding remarks to *Radio Retailing's* reporter, John Meiklejohn confirmed this viewpoint. "After all," he said, "the sales record is the best report a man can turn in. We vary our quotas with the season and according to the ability of the man. If he fails to meet them his case is given individual attention. Because sales candidates are carefully selected, having this 'new freedom' in mind, labor turnover has been less than ten per cent."

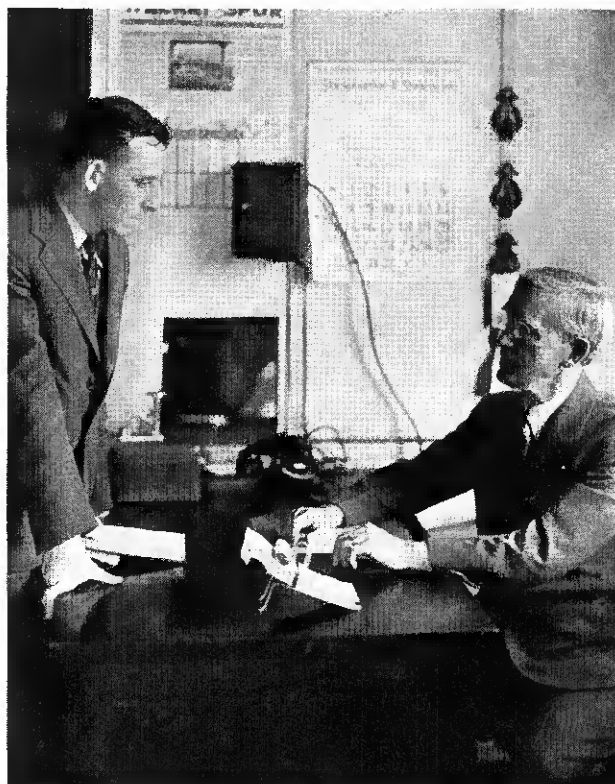

"Salesmen can book more business by 'exposing themselves' to many new people every day than by back-tracking on promises," John Meiklejohn (right) and crew-manager Maurice Feingold agree

Tubes— on

CONSIGNMENT

Franchised dealers report favorably on this plan after six months' trial

SINCE March a well known tube manufacturer has been consigning its product in certain territories. For the past three months it has operated entirely on this basis. Two weeks ago the editors of *Radio Retailing* interviewed 17 dealers, whose shelves for half a year, have been stocked, in part, with tubes consigned by this concern. Without exception these dealers like the plan, they claim increased sales and more net profit.

Other, non-franchised dealers were contacted. Where an adverse opinion was voiced it generally was to this effect: "I prefer to carry title to my own tubes and to sell them as I please. Do not want second-party supervision of my stock or merchandising methods. I dislike the responsibility of looking after consigned stock." Or, "Consignment annoys us. Tube turnover is too rapid for that. Frequent inventories cost money."

THE machinery of the tube consignment plan operates quite simply. Branch houses and district managers, reporting directly to the tube maker, exercise frequent supervision over the tube stocks, sales and requirements of the jobber and dealer. The jobber is held responsible for the credit of the retailer and for control of his consigned stock. Once a month each dealer inventories his tubes and adds to the previous month's inventory shipments received in the interim. By the subtraction method he then determines sales for the month and the amount due his jobber. It will be noted that the word "consignment" thus means: "Cash, 30-days on all tubes sold."

But let those interviewed speak for themselves. First, a large city dealer, located in the heart of a price competition district: A. J. Liss, of S & S Radio, 125th Street, New York City.:

QUESTION: Mr. Liss, it is claimed that the consignment plan maintains list prices. Is this borne out by your experience?

ANSWER: It certainly is. We are the only Tung-Sol outlet in this entire neighborhood and have been since we took on the line. Although we cut prices on all other tubes to meet competition we have always sold this particular brand at full list. There is no cut-price competition to meet on this line. Unauthorized dealers can't do much damage with their limited, bootlegged stock.

Q: How many lines of tubes do you handle?

A: We have nine at present. Four are the so-called "legitimate" lines, with nationally known names. The others are 29c. and 39c. items bought up in job lots, "as is."

Q: How is your tube volume split up?

A: Our best volume, dollars and cents, is in the cheap tubes because we are in a neighborhood where such merchandise sells best. The consignment line outsells the other standards though. Our 6 months' business, August, 1931, to February, 1932, will give you a good idea of how much. Total tube volume, at retail: \$7,148. Consignment tube sales: \$1,713.

Q: Do you carry a more complete stock of Tung-Sol's than other lines?

A: Not particularly. Right now our total stock is worth about \$2,700 and there happens to be about \$100 more in the consignment shelves than we have of the next best selling line. Shelf space is worth too much money to us to permit us to load up with tubes just because we don't have to pay for them when we order.

Q: Have you found the accounting work required by the consignment tube manufacturer difficult?

A: Difficult? It makes our work easier. We make out a sales slip for a consignment tube just as on any other item and our bookkeeper merely collects these slips and enters their sums, itemized by tube types, in a separate ledger. An inspector calls on us once a month and asks how many and what types of tubes we have sold. Usually he takes our word for it.

Q: Do you push the consignment tubes over other makes?

A: Yes we do. Because they are sold strictly at list we consider it practical to offer our serviceman a five-cent commission on each tube that he sells.

Q: How can you sell your consignment brand at full list when other brands are cut?

A: By sheer salesmanship. We point out that a line on which prices are universally maintained must be better. In addition we offer a 6 months' guarantee while there is only 3 months on the next best seller. Our service-salesman already has created neighborhood acceptance for this line. We are profiting on our own advertising and promotion effort because of an iron-bound franchise that really works.

Q: If other tube manufacturers could really enforce list prices and territorial franchises would you still prefer to do business on consignment, Mr. Liss?

A: No. On the contrary, I would prefer to buy my tubes outright in order to take advantage of the better discount but so far the consignment plan is the only one which does give any kind of protection.

Q: What has been your experience with replacements on consignment tubes?

A: They are no more severe than other standard brands. The manufacturer never questions our returns.

Q: Can you think of anything a consignment tube

manufacturer could do to make his proposition still more interesting to you?

A: Yes, run more advertising to back up our claims that the tubes are really worth full list. We do a good job promoting the merchandise by word-of-mouth ourselves but advertising would help us to sell a greater quantity.

HOW does Mr. Liss' experience jibe with that of the small town dealer? Here is what a radio merchant in a Kansas town of 16,000 has to say:

"Of especial value to me, with my limited capital, because I can now carry a complete assortment of tubes, including even the newer types—over 25 catalog numbers altogether—and can keep this stock replenished at all times. When I sell a tube I put this money aside. At the end of the month I pay only for what I have sold. My business in the consignment brand has been increasing, in proportion, steadily—and I always sell at the recommended list."

Summarizing the opinions of eight consignment franchised dealers in six cities in the upper part of the Empire State, we arrive at these conclusions: Enables dealer to maintain a complete stock of all tube numbers at all times and at minimum capital tie-up; can, and must, sell at list (because no cut prices have been established on this make of tube and because dealer will lose desirable franchise if he does not comply with its implied terms); if prices drop, dealer suffers no loss; simplifies bookkeeping and, lastly, can establish a repeat demand for a specific brand of tube and at a profit.

FROM the jobber angle, the statement of H. J. Zehner, president of the Ignition Service & Supply Co., Inc., Albany, N. Y., may be taken as representative: "We like the plan very much," he told the writer. "Our tube business has quadrupled within the past six months. Seventy-six per cent of our dealer monthly consignment reports arrive on schedule. Credit losses have been surprisingly few—less than one per cent. You see, with consignment goods the dealer is, to some extent, criminally liable if he cannot account or pay for each item. It gives my men time to act in a sales promotional capacity rather than as a high-pressure order clerk. The dealer now specifies just what he needs, and as often as he needs to. I have closed many desirable tube contracts with retail outlets since I have had this consignment proposition."

A New York City jobber, with ten months' experience behind him, reports, "not a nickle yet lost on dealer credits. Our boys are turning their consigned stock at a 4.5 annual rate. They get approximately the same discount as on tubes of other makes. I understand." this jobber concludes, "that a most gratifying number of new wholesaler accounts have been signed up by the manufacturer since this plan went into effect and that, in turn, these wholesalers have annexed many new dealer tube contracts."

The retail consignment plan for radio tubes is still in its infancy. It is quite possible that while this method of ultimate selling may function ideally for the manufacturer in question, and for the type of distributors and dealers selected, it will not work with other tube makers. The initial set-up must be suited to the special demands on capital and on first-hand territorial control which such a policy involves.

Radio Retailing will follow closely the progress of this method of selling tubes and will report any further significant developments when, and if, they occur.

Watch Replacement Parts

this year, says

R. N. Swanson

*Vreeland Radio Corporation**



REPLACEMENT parts business is, in our estimation, entering the 1932 selling season with everything in its favor. This is the way we reason it out: There will be less set business than in 1931 due to the general low level of business, possibly only half as much. However, many people who cannot afford to replace receivers will find it advisable to replace parts incorporated in their old ones in order to keep these in service. The dealer who stocks such parts should profit.

It is not essential that such a dealer carry a large stock of transformers, loud speaker parts, etc., for these involve considerable investment and turn over slowly. He should, on the other hand, stock a good assortment of by-pass and filter condensers, small fixed condensers, volume controls, fixed resistors, replacement sockets and accessories such as lightning arrestors, aerial wire, antenna kits and phone plugs—items which cost little and turn often. On these, gross profit should be not less than 40 per cent.

A worthwhile market, we feel sure, can be created by calling upon prospects to whom radio equipment has been sold in the past. The dealer's first aim, of course, should be to sell a new set. Failing that, the customer should be persuaded to modernize his old one, bring it up to peak performance.

In practically all cases repair work, labor and parts is cash business. This is another thing to consider at a time when ready cash is hard to find. The successful 1932 dealer, we would say, will be one who puts an equal amount of effort in both the service and sales divisions of his business.

*Since early 1931, when it opened its doors as the Winner Radio Corp., Vreeland Radio has specialized in the distribution of parts to servicemen and transmitting amateurs. Headquarters for "International" resistors and similar quality products, this concern is locally recognized as an authority on component business.



OIL

For the home, and for the kitchen range As a complementary line for radio dealers

**THIS MAN
can be sold an
OIL BURNER**

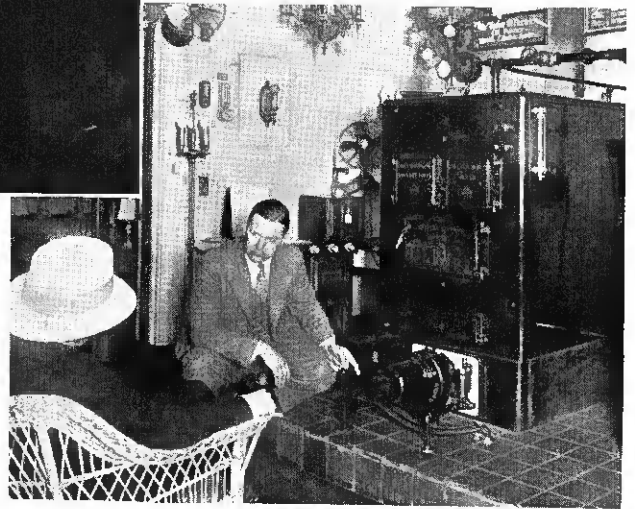

FOR thousands of radio dealers the electric refrigerator proved a life saver this summer. These merchants demonstrated their fitness to sell, successfully, a major appliance and one which must be promoted. This leads to the question: If the volume of radio business should continue to prove insufficient to support a radio dealer, what other comparable product might he consider?

How about oil heating? This subject includes oil burners for the kitchen range as well as for the furnace in the cellar.

Last month the writer talked with sales managers for oil burner concerns and with many oil burner retailers. These conversations lead to the conclusion that, for some radio dealers, the stove heater might be a more satisfactory article to handle than house heating equipment. The technique of selling and installing range burners is quickly mastered. The market is extensive, easily reached and quite unsaturated. The better types retail at from \$25 to \$45 per complete job—usually two burners to a coal stove. People whose incomes run from \$3,500 per year or less are the best prospects; apartment dwellers the poorest. One hundred dollars invested in

stock, a specimen installation, a day with a factory representative and the radio dealer is ready to go.

But with oil burners, either for furnaces or stoves, the dealer *must* get out to sell. "It's a job for strong leg muscles," they told me. Furthermore, and this point universally was agreed on, the man who plans to sell oil burners for home heating, from the initial estimate to the final installation and service inspection, must gear up to it. If he would act as a full capacity dealer he must master the fundamentals of heating engineering and he must be, or must employ, a licensed plumber. Oil burner installations have to pass state and city inspections. In other words, building an extensive oil burner business is done by the specialty type of retail outlet.

THIS very fact plays into the hands of the live radio man. By previous training and experience he is accustomed to selling semi-technical devices for home use running into major cost proportions. He already knows how to book orders "off the parlor rug" as well as behind the counter. He has the servicing foundation and he has a ready made list of ideal prospects. After all, it's a selling proposition—the job calls for a real brand of

H E A T

promotional salesmanship rather than for plumbing experience. The latter can easily be hired.

The sample house burner, plus the boiler or furnace, will net the dealer approximately \$450. Oil burners sell for from \$400 to \$850. It is possible for the radio dealer who chooses to operate under a close cooperative, or sub-agent, agreement with an oil burner specialist, to get along on a much smaller investment.

No, the oil burner business is not a catch-as-catch-can game. It's a long pull, with a fairly long season—much of which overlaps that of radio. The right kind of radio dealer, however, if he acquires the necessary training and gives the heating business the attention it demands will find it as profitable a line as refrigeration. And for the majority who prefer quicker action for a less expenditure of time and money, there remains the range burner—which sells for the price of a consolette and in a market far less saturated.

How One Radio Concern Will Sell Oil Burners

AFTER a thorough survey of the possibilities of the oil burner market the Buffalo Nipple & Machine Company, N. Y., through its radio subsidiary outlet, the All Electric Company, has decided to enter the liquid fuel heating field in a big way. With the close cooperation of the manufacturer, a sales force of 15 men—on a 12 per cent commission basis—has been organized, trained and placed in the field. A 1932-33 sales quota of not less than 150 burners has been accepted. The attractiveness of oil heat was the deciding factor which caused George Kiper, Jr., sales manager of these affiliated companies, to make this favorable decision. Naturally, the salesmen have been drilled also to stress this line of thought.

"Economy is the strong talking point in any sales presentation these days," explains Mr. Kiper. "The men will feature this in their solicitations. Oil, at today's price, runs 25 per cent less than coal and almost half the cost of gas. Then the advantages of even heat, thermostatically controlled, and the freedom from fire tending and from ash carrying are easily understood, and very much desired. Oil used in oil burners has got to come up to government specifications and its heating value is definitely known and constant. You cannot make the same statement in regard to either hard coal or gas.

"Complete oil burner installations run lower in price this year than ever before, and the terms are easier. Ten per cent is the minimum down payment and the balance, like the plan that proved so popular in refrigeration, may be taken care of over a period of two years. Again oil burners have been brought up to the point of perfection where, from my study of them, service, or the need of it, is no greater than on the average electric refrigerator, and that, as you know, is not much."

"Most of our men," continues Mr. Kiper, "have had sales experience with products far nearer the saturation point than oil burners. They get real enthusiastic, therefore, about the possibilities of selling a product in a market 96 per cent unsold. And at 12 per cent commission and an average price of \$550, installed, a fine income is assured with only a fair sales performance."

Concluding his interview with our representative, Mr. Kiper said: "The radio dealer who takes on an oil burner now will get the finest kind of cooperation from its maker. The concern we are doing business with gave us a factory man to stay with us and build this thing up from a solid foundation. For the radio dealer who must add some other major activity immediately my experience, so far, leads me to recommend the oil burner as his best bet."

In contradiction to the popular belief that only the well-to-do can be sold an oil burner, the following figures, supplied by a well known oil burner manufacturer, will be illuminating: Of all the oil burners now in use . . . 37 per cent are in homes valued under \$10,000 and 83 per cent in homes valued under \$20,000; of all the oil burners now in use . . . 87 per cent are installed in the homes of persons whose income are less than \$10,000 per year.

In conclusion, these words of caution from the head of a finance house which discounts oil burner paper: Do not fall for \$25 down, get at least ten per cent with the order—and handle only a known burner of reputable make.

"HOT SPOTS"

The Oil Burner—

for House Heating

Sells for \$400-\$850

Averages three service calls a year

A receptive market but must be intensively cultivated

To estimate requirements and install calls for trained and licensed men

Requires an initial investment of from \$200 to \$600

Season—NOW, August all through winter

To sell—must have heating knowledge plus strong leg muscles

The Range Burner

Sells for \$25-\$45

Fits in the kitchen coal stove

For cooking and room heating

On market eight years

Rapidly growing in popularity

Quarter of a million now in use

Practically no service expense

Radio dealer can sell and install

Initial investment, \$100

Town and rural market equally unsaturated

Sold by personal calls and word-of-mouth advertising

Season—NOW until December. Secondary season, Feb.-May

Ray York
DEALER

John Fetyer
INSTALLER

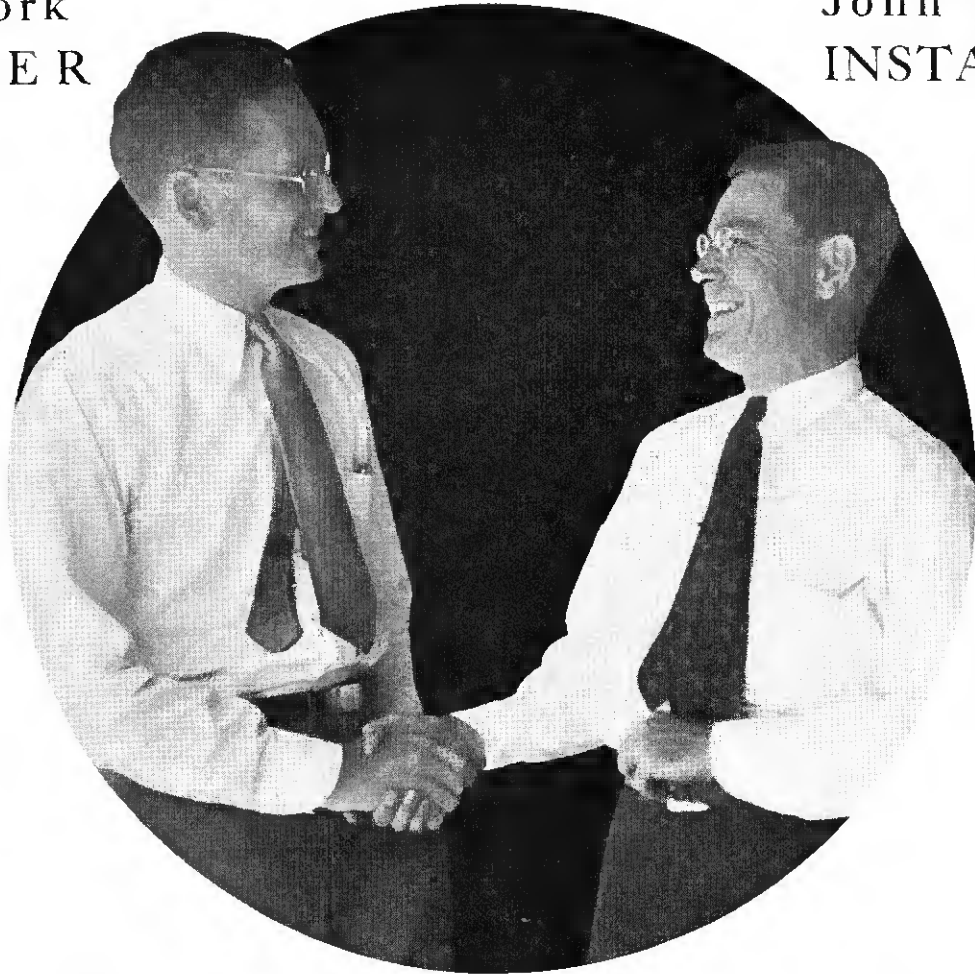

Shake hands *with Your*

CHICAGO, home of the Tinker - Evers - to - Chance baseball combination, now has another cooperative team—radio dealers who are playing the automobile-radio game with special service stations. Due to this pooling of resources sales of one particular make of automobile-radio equipment have run over 1,500 sets so far this year.

"It isn't in the cards for ordinary radio dealers to make installations," says Stanley Hasemeier, president of the Stanley Warren Company, of that city. "In the first place they have had no place to do it. The car owner would drive up in front of a store and leave his machine, and the radio service man would fuss at it in an ineffectual sort of way. When he tore up the upholstery to put in an aerial he usually left a messy job. Until special service stations came along, automobile radio simply didn't click."

Scattered over Chicago today are a group of associated automobile-radio service stations, each one handling installations for local electrical, radio and automobile-selling firms. After the dealer has sold a job he either drives the car to the service station or directs the owner to it.

"Associated Automobile Radio Service Stations" is really only a name. There are no dues, no meetings, and the only link between these shops is the fact that they are mutually interested in the sales of auto-radio instal-

he runs an
**AUTO RADIO SERVICE
STATION**



lation labor and so pay their portion of the cost of cooperative ads. The cooperative space contracted for by the group not only secures work for itself but also advances auto-radio sales for all Chicago dealers.

According to Don Hucke, of the Stanley Warren Company, virtually all of the cars in which automobile radios are installed are less than a year old. Installation charges vary according to the number of cylinders in the car and whether or not an aerial must be put in. All dealers and service stations carry cost sheets which enable men to show the prospect exactly what the job will run on his particular make of car.

"The dealer who sells the automobile radio makes a flat payment to the service station for the installation job," president Hasemeier stated. "Usually it amounts to the down payment. The custom of selling on time is growing in Chicago and this financing is done by means of a chattel mortgage on the entire car. The charge is around \$14 for financing. Where the automobile has not yet been paid for, the finance company takes over the previous paper, pays it off and issues new notes to cover the entire job.

"The best prospects for automobile radios are as follows: salesmen, people who go on cross country trips and women who drive a great deal during the day. Strangely enough, youngsters with snappy sport cars have not proved good bets. The chief interest of many purchasers seems centered on ability to get baseball news. Installations made in Chicago are able to pick up Cincinnati, Davenport, St. Louis, at any hour of the day."

Every time the traffic stops Hasemeier's salesmen give a demonstration of automobile radio to other car drivers. If 7 cents a mile can be considered a fair cost for transportation, the average cost of a real demonstration to a prospect is 70 cents. Frequently the salesman shows off the radio while parked alongside the curb.

"Radio dealers have lists of people who have bought radios from them and have their confidence. It is a relatively simple job to sell such people radios for their cars. The truth is, however, that the automobile houses are taking too much of this business away from the radio merchant," states Hasemeier.

"I admit that the easiest time to sell an automobile radio is when the car is purchased, but there are any number of cars in use that can be so equipped, and the fact that the radio can be moved from car to car widens the market greatly. I do not think that retail automobile radio selling is a transient thing as car makers would have to pile a lot more money on the price if they decided to add the radio as standard equipment. Right now they are fighting to keep down prices. In my opinion it will always be a specialty to be sold to the car owner."

One of the dealers who patronizes the Stanley Warren service station is the O. R. Martin Company.

"We have sold 15 sets so far," says Ray York, the manager. "Any radio or electrical dealer with an outside selling organization will find automobile radio an ideal item, in the fall as well as during the earlier months. He should obtain all the automobile license numbers in his neighborhood. These addresses are my best leads."

Partner—

Look! Amazing **AUTO RADIO OFFER!!**
PHILCO *Transitone*
 COMPLETE AND INSTALLED IN YOUR CAR—*Now Only*
\$12.50
 QUICKLY INSTALLED
 Balance in 12 EASY PAYMENTS

PHILCO *Transitone* is sweeping the country! Accepted everywhere as the best 100% satisfactory Automobile Radio. Because of its marvellous performance and the new low price, thousands are being installed every day. And soon you can have this marvellous new radio installed in your car immediately... today... this week by paying only \$12.50 down; the balance in twelve convenient payments.

FREE DEMONSTRATION
 Yes, we will gladly give you a free demonstration of this brand new and without the slightest obligation you may test it for tone, selectivity, range and all-round performance. You will simply be amazed.

And remember, after you've demonstrated this magnificent automobile radio in your complete satisfaction, you pay only \$12.50 down, one is installed in your car, and you drive away to all that's best on the air.

Hurry! Limited Offer
 So by all means look over the addresses listed below, note the one nearest you, then call at once in order to be sure of prompt installation. Think of just \$12.50 down and you take radio with you on vacation, here in the fall games, the Democratic National Convention, the Olympic Games, your favorite programs—all as you ride.

ASSOCIATED AUTOMOBILE RADIO SERVICE STATIONS
 (Note: Transistone is now You Buy A New Car)

NEAR SOUTH 2428 South Parkway VICkey 818 Mr. E. W. Larabee	SOUTHWEST 6632 N. State St. ENGlewood 4241 Mr. H. Hayes	SOUTHEAST 2133 E. 71st St. Ebbles 9411 Mr. S. B. Terrell	WEST 3047 W. Washington E.S. Edward 1101 Mr. E. H. Jennick	NORTHWEST 2919 Lawrence Ave. N.W. Stone 0720 Mr. C. H. Dorebeck	OAK PARK 447 Madison St. ALSton 8000 P.C. Hill 1041 Mr. Earl Kuhnlein
SOUTH	SOUTHWEST 6632 N. State Ave. PHilmore 2871 Mr. J. S. Krueger	NEAR WEST 2133 E. 71st Ave. ARSton 0814 Mr. J. Johnson	NORTH 6636 Broadway N.H. Drake 8114 Mr. Herbert Kenner	EVANSTON 1015 Davis St. DANy 1629 Mr. S. Robinson	

LIMITED OFFER 10 DAYS ONLY COME IN NOW



This is a sample of the cooperative advertising on auto-radio paid for by Chicago's installation stations. It benefits dealers who sell but do not install, as well as its sponsors

Windy City dealers have quickly recognized the value of "rolling demonstrations". Their cars are auto-radio equipped and every time the traffic stops many motorists are made auto-radio conscious



NOW is the time for

Come to the

By Lloyd

Shipstead, and Capper (among the first to make use of transcriptions for broadcasting to their constituencies), and congressmen like Howard, of Nebraska, and Horr, of Washington, who records ten programs per week, all point to the importance these politicians attach to radio.

OF COURSE they are meeting with competition. Running as congressman-at-large for Texas, Chesney Jurney supplemented his extensive campaign through the huge Lone Star state with a radio-equipped truck, probably the first of its type. After running through the streets of Washington this truck made the long trek to Texas, a thorough round of the state, and now is back in the Capitol again. This trip proved thoroughly the reliability of the installation.

Built on a special Chevrolet body, this typical "political" truck contains a bunk for the operator, a platform for the speaker, which can be folded over out of the way when on the road, a horn mast in the rear so arranged as to be collapsible, and, of course, a complete turntable, microphone, and amplifier installation. It was designed for battery operation since power might not be available in many communities. Its "class B" amplifier is economical in operation, this particular truck using only one set of plate batteries which lasted for a ninety-day trip. Filament current was also battery-supplied. There was no trouble in recharging the storage battery en route from the automobile's generator.

A 78-r.p.m. turntable was placed with its spring motor on a small table, with a rack for the records. A jack, which was the only piece of the apparatus to give any signs of difficulty on the entire trip, was used to connect its electric pick-up head with the amplifier or to switch the amplifier to the regular carbon type of microphone which is specially suited for a speaking voice. By judicious location of all the equipment, the possibility of feed-back between the mike and speakers was reduced to a minimum.

For the output equipment, a large Racon horn permanently fastened with the bell projecting out from the front overhang of the truck, and two smaller such horns which could be suspended over the back of the truck on the collapsible mast provided an adequate way of delivering undistorted speech to a wide audience.

A number of specially made transcriptions were used while the truck was on its trip, giving the campaigner and his helper an opportunity to rest their voices. Crowds did not seem to mind this substitution of the "canned" for the physical and greeted the candidate on the back platform as he appeared to make "closing announcements" himself by means of the microphone immediately connected in.

NOW is the time for all good *radio* men to come to the aid of the parties." That's the message that is clicking out of the headquarters' offices of both the Republican and Democratic Committees as the battle for the Presidency approaches.

And this message is not without significance for good radio men who are on the job. It means real business for them, even at this late hour. Because broadcasting is going to do a lot of the electioneering this year of economy and modernism. Not only are senators and representatives who want to return to their jobs in Washington going to tell their constituents how good they have been and how much better they will be . . . if elected, but in addition, field men equipped with field equipment, trucks, public address systems, portable turntables and suitable recordings of those speeches, will multiply the activities of many candidates for offices even in the most remote corners of the election districts.

Already, the caravan of radio trucks has left Washington. Speeches carefully prepared and rehearsed during the spring and early summer months have been recorded and are being forwarded to campaign headquarters and to stations. One organization in Washington, the National Radio Equipment Exhibitors, Inc., has made over 500 such recordings for congressmen in the past months.

Senator Nye believes that the electrical transcriptions he had made helped him win his primaries for he had practically no newspaper support, could not personally campaign all over his extensive territory and had to lean entirely on broadcasting.

Activities among senators La Follette, Nye, Frarazier,

all good RADIO men to

aid of the parties

Jacquet

SOUND trucks such as this one can be turned out, complete, with body and installation for about \$2,000. Parts used in constructing the amplifier were in stock. The circuit was standard and easily checkable, a valuable characteristic on the road, when time was valuable, and a schedule had to be followed practically to the hour.

Standard parts were used because of their immediate availability in shops and service stations along the route. No spare parts, except plate batteries, tubes and a bunch of phonograph needles were carried. This shows how much reliance was placed on the apparatus that actually went through 22,000 miles of travelling!

Made-up, manufactured public-address equipment may, of course, be used. In fact it would be advantageous to do so.

Adding the bunk to the equipment and including an operator besides the driver and political crew may seem to be an extraordinary precaution. But it was decided that an experienced technical man would more than pay for his keep by providing a smooth-running sound truck, which in turn would more than keep the candidate pleased and up on his toes. No repairs were needed on

this trip, fortunately, but the service which the operator rendered in his daily thorough inspections of the equipment, careful watch of the battery condition, handling of the microphone, and the quick, business-like change-over from record to mike and vice versa kept him busy just the same. No little success was attributed to him.

Plans now being carried out by the headquarter camps of both Republican and Democratic committees, state, regional and local, indicate that sound trucks will be part of the extensive ballyhoo machine to tell the dear old public about the candidates. The necessary economies which have had to be practiced this year due to the shortage of election funds call for wise spreading of dollars, and cutting down on personnel for public speaking. These factors practically write a recommendation for radio and the public address system, as well as the use of record transcriptions. Last-minute plans are being worked out now on the basis of the money available in the smaller localities. Automatic apparatus will have to be called in promptly and possibly suddenly. There's when "good radio men" can come to the aid of the parties . . . for their own benefit!

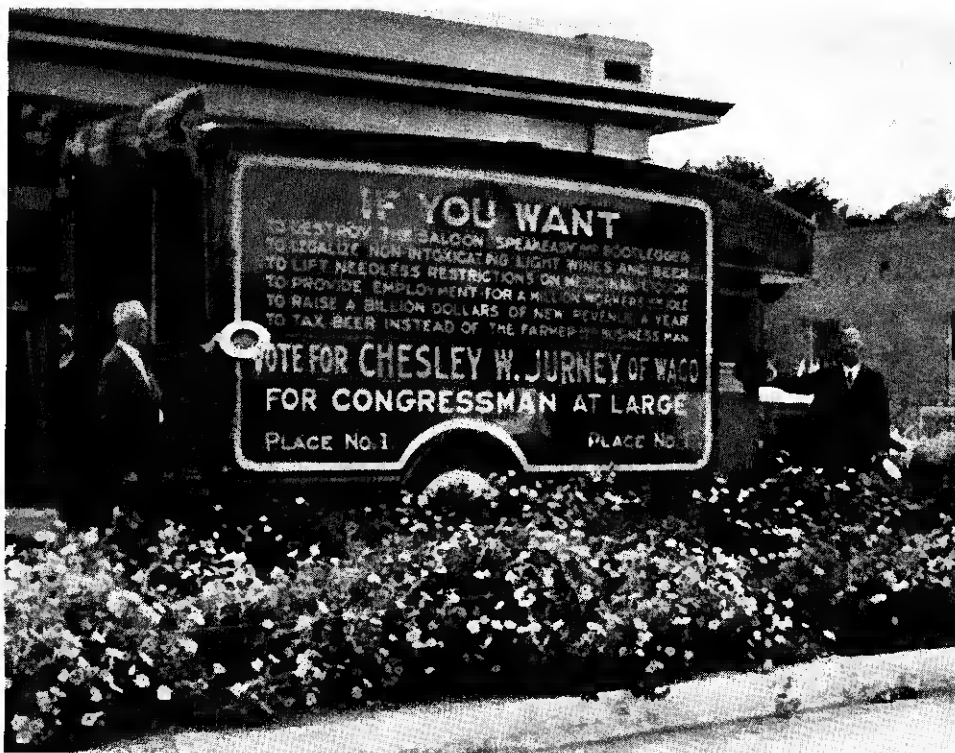

Sound trucks—the political "spellbinders" of the future

Reorganized RMA Now

September, 1932

Other News of the Month,

MEMBERS, MEETING IN CLEVELAND, ENDORSE PLAN UNANIMOUSLY WILLIAMS REELECTED

*New Directors All Key Executives, a Majority Set Makers—
Promotional Activities Already in the Works*

HIGH promise of a new, and healthier, era in radio history was seen in the unanimous indorsement, at Cleveland, Aug. 23, by the membership body of the Radio Manufacturers' Association, of radically different by-laws and plan of operation for this key organization of the industry. On that day, at the Hotel Cleveland, RMA was officially declared a reorganized and revitalized body, with new concepts as to its purposes and objectives; with a newly proportioned board of directors and with new enthusiasm.

In the RMA reorganization, uniting all industry elements and factions in a solid industrial front, leading receiving set manufacturers took the reins for direction of the industry's programs and policies, being given dominant control.

Fred D. Williams, of P. R. Mallory & Co., Inc., Indianapolis, was reelected RMA president by unanimous vote of the association's new board of directors. Then comprehensive programs were founded to promote every unit and interest in radio.

The new board, in control of RMA destinies, comprising twelve leading set manufacturers, three tube manufacturers, two parts and accessory manufacturers, and one director representing sound equipment manufacturers follows:

A. ATWATER KENT,
President, Atwater Kent Mfg. Co.
JAMES M. SKINNER,
President, Philco Radio & Tel. Corp.
W. ROY McCANNE,
President, Stromberg-Carlson Tel. Mfg.
J. R. McDONOUGH,
President, RCA Victor Company, Inc.
WILLIAM SPARKS,
President, The Sparks Withington Co.
POWELL CROSLY, JR.,
President, The Crosley Radio Corp.
J. CLARKE COIT,
President, U. S. Radio & Television Corp.
ARTHUR T. MURRAY,
President, United American Bosch Corp.
A. S. WELLS,
President, Gulbransen Company.
FRANKLIN HUTCHINSON, JR.,
President, Kolster Radio, Inc.
PAUL B. KLUGH,
Vice President Zenith Radio Corp.
B. J. GRIGSBY,
President, Grigsby-Grunow Company.
ELMER T. CUNNINGHAM,
President, RCA Radiotron Company, Inc.
S. W. MULDOWNY,
Chairman of the Board, National Union Radio Corporation.
GEORGE LEWIS,
Vice President, Arcturus Radio Tube Co.
FRED D. WILLIAMS,
Vice President, P. R. Mallory & Co., Inc.

LESLIE F. MUTER,
President, The Muter Company.
RICHARD A. O'CONNOR,
President, Magnavox Company, Ltd.

Vigorous cooperative action was promised by the new directors, most of whom were present. Many projects were actually started. President Williams explained in detail the reorganization plan and how it will make possible direct action and result-producing control by the industry's leaders. The latter, present at Cleveland, pledged their active and personal support. This action was made by such personalities as the following company presidents: Captain William Sparks, "Sparton," James Skinner, "Philco"; Roy McCanne, "Stromberg"; McDonough, RCA Victor; J. Clarke Coit, U. S. Radio; A. S. Wells, Gulbransen; and Franklin Hutchinson, Jr., Kolster.

Interest Presages Success

In the Grand Ballroom of the Hotel Cleveland top representatives of over fifty concerns were present. All payed their own expenses. Some came by airplane. These actions, despite business conditions, were interpreted as a testimonial of the interest and support to be expected for the new organization.

Several new candidates, notably the Zenith Radio Corporation and the Grigsby-Grunow Company, both of Chicago, were elected (readmitted) to membership in the RMA and also to places on its directorship.

The creation of four distinct divisions, to look after the special interests of the manufacturers under the four classifications, was another feature of this meeting. These are the Set Division; the Tube Division; the Parts, Cabinet and Accessory Division, and the Amplifier and Sound Equipment Division. Following are the chairmen of these sections: Sets—Arthur T. Murray, president, United American Bosch Corporation; Tubes—S. W. Muldowny, National

SHOW DATES

Philadelphia Sept. 26-Oct. 1
Fifth Annual Electric and Radio Show

New York Sept. 19-25
Hotel Edison Radio and Refrigeration Show

Minneapolis Sept. 26-Oct. 1
11th Annual Northwest Radio, Electrical and Home Appliance Show

St. Louis Oct. 17-22
8th Annual Southwest National Radio Show, Electric Appliance and Radio Program, Sponsors Exposition

Union Radio Corporation; Parts, Cabinet and Accessories—Leslie F. Muter, the Muter Company; Amplifiers and Sound Equipment—Richard A. O'Connor, president, Magnavox Company.

All four division chairmen also were elected vice-presidents of the RMA and, with President Williams, will compose its executive committee, finance committee and budget committee.

E. N. Rauland, of the Rauland Corporation, of Chicago, was reelected treasurer of the RMA. The association's personnel also includes Bond Geddes, executive secretary. The Chicago headquarters office, at 307 North Michigan avenue, will be continued, but the New York office of the association will remain closed indefinitely.

Following adoption of the new by-laws, embracing the reorganization plan, and meetings of the four new divisions, the new board of directors held a meeting and started vigorously at work on many industry activities which will be pressed in the future.

Two-Way Auto-Radio Publicity



Universal, South Bend, Ind., gets publicity for its auto-radio business through a loud speaker mounted in the right rear window aperture of the owner's own car. A rear tire cover also tells the story.

Officially Approved

Arranged for Busy Readers

New York, N. Y.

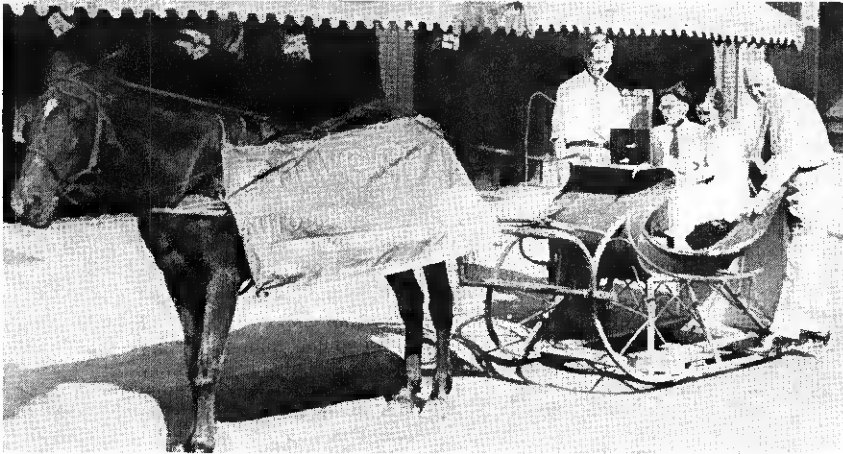

Get a Horse

Left to Right: A. U. Cloud, C. R. High, Hortense Shirley and R. E. Cloud, who dragged this old-time sleigh out of a deserted barn to use it effectively as publicity for auto-radio in and around South Bend, Indiana. P. S.—They had no trouble suppressing ignition noise!

Grunow's Line About Ready Refrigerator Samples Nearing Completion—Wanamaker, Coots, Macke Plan Campaign

William C. Grunow's new concern, about which there has been much speculation, has established temporary headquarters in the Bell Building, Chicago. The Grunow Corporation plans to ship samples of its new, low-priced refrigerator in the near future, we are informed by Duane Wanamaker, in charge of sales. Aided by Mr. Wanamaker, E. D. Coots and Earl W. Macke, gentlemen who have all been associated with him for some years, Mr. Grunow has mapped out his sales campaign. He states that the Grunow Corporation has already arranged with many leading distributors to handle the new product.

M. W. Kinney and Dr. J. D. Jordan, engineers permanently associated with the corporation, with the assistance of a co-operating group of consulting engineers, have produced a box which in their estimation will be a revelation to the trade. The new "baby", which has been jealously guarded, kept strictly to the laboratory, has passed rigid commercial tests and is now ready to see the light of day. It will be made, we understand, almost entirely in the Grunow plant.

The Grunow Corporation, incidentally, is close-held. None of its stock will be owned by outside interests.

And Now Typewriters!

With the advent of a new model, low-priced portable typewriter, the Royal Typewriter Company, New York, announces its intention of marketing it through radio trade channels. The new machine, "Royal Signet," answers a

need, it is claimed, that has been evident for years. The Signet model will list for \$29.50 and does away with the shift key.

"In our opinion," states W. J. Montgomery, sales manager of the portable division, Royal, "the average radio dealer should make an ideal person to promote this new, for him, activity. We are preparing an unusual sales campaign of cooperation with the radio industry."

We hear that Zenith intends to hold its list prices as is, absorbing the tax.

With Us Again



One of radio's names-to-conjure-with, that of Bill Grunow, is again very much on deck. This time he solos on refrigeration.

RADIO MEN PLAN CHICAGO EXHIBIT

Jobbers' Assoc. to Sponsor Advance Showing, in World's Fair Building, of "Modern Age" Appliances

A forward step which, it is claimed, will do much to "snap business out of it," has been taken by the progressive National Association of Radio, Refrigeration and Electrical Distributors. This association of jobbers has arranged with the World's Fair management to sponsor a "Modern Age Exhibition," which is to be held in advance of the Fair in the unique Travel and Transport Building from October 1 to 16, this year.

The exhibition, according to Chicago's Bob Himmel (Hudson Ross Co.), who will direct it, will supplant many individual shows which have been held here, there and everywhere in the past few years. "It will afford an opportunity," states Mr. Himmel, "for the manufacturers of radio, refrigeration, air conditioners and other examples of modern scientific progress to exhibit their wares in a central and truly conspicuous spot. Radio, refrigeration and air conditioning will probably absorb 90 per cent of the available space."

Approximately 100,000 people a month already visit the Fair grounds, paying ten cents per head admission. This virtually assures attendance and the show executives anticipate exhibiting to fully 750,000 people before shutting up shop. Negotiations are in progress to bring nationally-known stage, screen and radio stars to the exhibit, where a gigantic crystal studio-stage is being erected for their use.

The Travel and Transport Building is one of the first to be completed on the Fair grounds and will form an important part of the great, internationally attended Fair in 1933. It is equipped with a unique dome which is completely suspended from exterior supports, entirely eliminating interior columns and bracing. This construction economy, according to H. G. Erstrom, executive secretary of The Modern Age Exhibition, is one of the things which will permit the management to offer greater space at cheaper prices than ever before. Seventy-three thousand feet of floor area is available.

Radio Products Re-Established

The Radio Products Corporation of 548 South 11th Street, Newark, N. J. (not to be confused with Radio Products of Dayton, Ohio) has been re-organized with Montgomery Carrott at its head. The concern plans to produce a small midget receiver, developed by Dr. Earl L. Koch,

Next Month, Specifications!

"Radio Retailing's" 8th Annual Specifications Number will be published next month, October. Here will be listed again all current models of broadcast receivers, phonograph combinations, shortwave, automobile and portable sets made in the U. S. A. As usual, list prices, cabinet descriptions, wavelength range and the extremely useful tube lineup listing, available nowhere else, will be given.

Watch your mails for this valuable issue, then keep it constantly on hand as a daily sales aid—as you have in past years.

Delegates to Canadian Conference Guests of "Radio Retailing"

Radio Business in England Shows Yearly Increase, Says Ellis

Returning to England via New York, C. O. Stanley, representing Philips Lamps, Ltd., and R. Milward Ellis, with Pye Radio, Ltd., both of London, were luncheon guests of *Radio Retailing*, August 25. Messrs. Stanley and Ellis were the delegates of the British Radio Manufacturers' Association, at the Imperial Economic Conference, held last month at Ottawa, Canada.

"The actual results of the Imperial conference will not be known until the Hon. E. N. Rhodes presents his budget speech before the Canadian Parliament, on October 6th," stated Mr. Ellis. "Those matters of tariff, taxation and content affecting the radio industries of the United Kingdom, Canada and, to a great extent, the export trade of the United States, will become effective at once, with the announcement of the resolutions by Rhodes.

Mr. Ellis, at Ottawa, was successful in his efforts to secure a uniform "Em-

pire Content" as a basis for tariff requirements. Branch factories in Canada of United States companies will be chiefly affected by the new rulings and changes in factory operations may be necessary.

Mr. Stanley stated that radio sales in Great Britain have increased steadily every year since radio became commercially practical. Last year was no exception and this coming twelve months is expected to witness the sale of 2,000,000 sets—the greatest in English history. This prediction has been confirmed by the flood of orders, totaling \$173,000,000, resulting from the recently closed British Radio Exposition—an outstanding success.



RUDISILL

J. L. Rudisill, to whom *Shaw's, Inc.*, Charlotte, N. C., safely entrusts its wholesale replacement parts business

"Stude's" Bootleg Radios

University of Notre Dame limits the use of private owned radios among the student body to those having average grades of 90 per cent in the previous semester's work. It is believed that only the exceptionally brilliant students can study efficiently with the distraction of radio entertainment present. The rule has been in effect for a year and is considered a satisfactory solution of the student radio problem. About 23 per cent of the students are eligible to maintain radio sets in their rooms. Small crystal sets and miniature battery sets that can be smuggled into the residence halls are popular with 77 per cent of the "studes."

RCA Shareholders Increase

Shareholders of the Radio Corporation of America numbered 108,833 on June 30, 1932, an increase of approximately 5,000 during the first six months of the year.

A year ago shareholders of the corporation numbered approximately 93,000, and in 1928 approximately 25,000.

Majestic "White Shirts" Meet in Chicago



Mid-West distributors got all "steamed up" at Chicago, Aug. 17, over Floyd Masters masterly presentation of Majestic's "Master Dealer Plan." Hand-picked dealers, specially trained, will constitute the front line of aggression in G-G's fall drive for both radio and refrigeration business

ST. LOUIS RTA ON SALES DRIVE

In a series of letters to all radio tradesmen in the St. Louis district, the St. Louis Radio Trades Association is stating the special opportunities for promoting fall business and encouraging its members to "Get Behind Radio—NOW."

"In addition to this mail campaign," states William Mackle, managing secretary of St. L. RTA, "we hope to start holding rallies to prove that there is a lot of radio business to be had by concentrated promotional effort."

The first letter contained this key-note statement:

"We are convinced that the possibilities of radio today are far superior to any other appliances. The sales of refrigerators and washers are reasonable and their season is closing. On the other hand radio listening is on the threshold of its peak season of the year. This fact offers radio tradesmen their opportunity and if the same amount of time and effort as was given to other appliances is now thrown into radio selling the result will be amazing."

Northwest Show to Adopt Free Admission Plan

The 11th Annual Northwest Radio, Electrical and Home Appliance Show which is to be conducted at the Minneapolis Auditorium, September 26 to October 1, will set a precedent by giving out through the exhibitors 30,000 free admission tickets. This step should guarantee a capacity crowd. The tickets will be given out by exhibitors to prospects, friends and customers. The general admission charge otherwise has been reduced from 50c. to 25c.

A more sensational entertainment program for show visitors than ever before will be a nightly feature. The big stage show will be followed by public dancing.

Triad Subdivides Territories

Triad Mfg. Company has found it advisable to subdivide some of its larger territories and install additional representatives.

Among the men to join its sales force are several who were formerly with Ceco of Providence.

L. Slowinski, Detroit, has been named to take care of the Michigan territory. Working from Cincinnati, Eric C. Matchette will cover southern Ohio and southern Indiana. E. C. Blakeman, Atlanta, Ga., has been appointed to take over the southeastern states including Georgia, Tennessee, and the Carolinas. Frederick Palmer, of Minneapolis, will represent Triad in Minnesota and the Dakotas.

Emerson Goes Through Jobbers

The Emerson Radio and Phonograph Corporation, of New York, well known to the music trades since 1915 and active in radio since 1923, is dispensing with its direct-to-dealer policy as rapidly as jobber connections can be established. The company's new treasure-chest model, as well as its popular line of short and long wave receivers, is going well.

Klugh and Grigsby to be RMA Delegates to Madrid Radio Conference

CLEVELAND, August 23—Important interests of radio manufacturers in the International Radio and Telegraph Conference to be held at Madrid, Spain, starting Sept. 5, will be in charge of Paul B. Klugh, vice-president and general manager of the Zenith Radio Corporation, and B. J. Grigsby, president of the Grigsby-Grunow Company, both of Chicago. These two radio leaders were appointed as the official representatives of the Radio Manufacturers' Association, at the invitation of the Spanish Telegraph Administration, under whose auspices the Madrid Conference will be held.

Broadcasting problems affecting radio and television will be considered at Madrid. Several months ago the RMA filed with the Radio Commission of Washington recommendations regarding television broadcasting and assignment of future broadcast channels in its development. These recommendations were made by the RMA Engineering Division, headed by Dr. C. E. Brigham, of Newark, N. J., and approved by the RMA board of directors.

American School of the Air

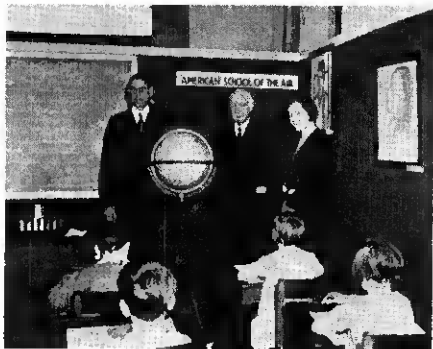

Secretary of Interior Ray Lyman Wilbur (left), with Dr. Augustus Thomas, Secretary of the World Federation of Educational Assns., and Miss Alice Keith, Broadcasting Director of the school, which the secretary visited recently. This is a model class room equipped with radio where the work of the school, now three years old, is demonstrated.

Music Merchants Assoc. in New Quarters

The new address of the executive office of the National Association of Music Merchants is Steinway Hall, 113 E. 57th St., New York City.

Major Hahn Resigns From Magnavox

The resignation of Major James E. Hahn, as chairman of the board, has been tendered the Magnavox Company, Ltd., of Fort Wayne, Indiana.

Major Hahn has long and favorably been known in radio circles. Originally with the Amrad Corporation, he later continued with Powel Crosley, Jr., and more recently has been in charge of the DeForest-Crosley operation in Canada.

The DETECTOR

The Big Men of the Miniature Movie game, according to A. D. V. Storey of the 16mm Board of Trade, are counting the days to their September 19th exposition booked at the Hotel Victoria, New York. One prominent radio manufacturer, so the story goes, will exhibit a new sound-on-film projector and organize a national exchange circuit to handle its films. Another is ready to spring a brand new list of disc and film talkies.

Frank Luther, creator of "Barnacle Bill, the Sailor", has just knocked out a row of a transcription for Sylvania which will take the air far and wide this month. Right in the middle of the festivities Frank demonstrates various rackets caused by poor tubes. Next time the listener hears a similar noise, Sylvania explains, he will rush out and test his tubes.

And while we are on the subject of programs—Philco busted a broadcast record during the week of August 15th when for five successive nights special spot programs were sent out from 123 stations, making a total of 615 periods. The reason for all this,—Philco's much ballyhooed National Word-Building Week.

To prove that the grass is just as green on this side of the fence: "The total value of radio equipment sold in Canada during the first 3 months of 1932 was \$2,155,623 as against \$4,167,715 in 1931, a decrease of 48 per cent. The average price dropped 42 per cent in this period."

Arcturus is bragging about its tube exports—with good reason. A tabulation just completed shows that the company's products are now jobbed in 76 foreign countries!

An optimistic note (and how we love it) is kindly supplied for this issue of "Detector" by Mohawk. This peppy outfit's refrigerator sales for the first half of the year are 125 per cent ahead of last.

Puzzle Answer: On page 37 of our August issue Moser and Suor's how-long-will-it-keep-milk-fresh contest was described. A bottle was placed in a "Norge" June 12 at 2:11 p.m., the box opened daily for inspection. What was your guess? The correct answer is 43 days, 3 hours, 31 minutes. The stuff went democratic on July 26.

Everybody likes to say "we told you so once in a while" and here's our chance. Frank Burke of Little Rock, Arkansas' 555 Inc., writes: "Notwithstanding the depression, June was the biggest Kelvinator month in our history. And, all theory of experts to the contrary (not ours, Mr. Burke) our leading refrigeration salesman is the man who has led our radio selling force for the past several years."

The Post Office Department, after nicking us an extra penny, partially

counterbalances by coming through with a bit of news which will keep dealers interested in rural trade. The department, we are told is arranging to publish in its Official Postal Guide a complete list of the number of letter boxes on each of the 42,000-odd rural routes. There routes serve nearly half the total population of the United States and by using the numbers direct-mail advertisers can do their stuff without possessing a single name.

The dealers up in Hartford, Connecticut, (where we visited last week) are taking their time pushing the new models because, they explain, price is the little tin god that dominates today's market—people buy last year's models quite as readily as the newer ones if they are cheap. Many of these dealers are actually still purchasing season-old sets from manufacturers who are only too glad to unload, even from mail-order houses.

These men, to our mind, are selling their profit-right for a mess of pottage. True, it is easier to let prospects buy cheap merchandise than to sell them new stuff but it is certainly not as profitable in the long run. The very fact that people are sufficiently interested in radio to buy old sets of their own volition is definite proof that they could be sold new ones!

Pungent Paragraph: "Radio still promises an inexhaustible future for those manufacturers and dealers who stress quality rather than cheapness, performance rather than price, seven-octave reproduction rather than three or four-octave reproduction, realism rather than tinny shadow, proud ownership rather than apologetic ownership". W. Roy McCanne, Stromberg-Carlson.

Salesmanager Metzger of Royal Type-writer contemplates marketing his concern's new \$29.50 portable "mill" through the radio trade, feels that we have the necessary entree into homes to sell a personal writing machine. The use of a new type face called "monotype" eliminates capital letters, cuts production costs.

New York's projected September show is off. Bernhart of the Madison Square Garden Corporation, who had it under his wing, tells us that it has been postponed until next year in order to better serve the interests of set manufacturers.

Columbia Phonograph is doing a nice job with its Aircell set, we hear. Clever merchandisers, these. Instead of trying to put out this stuff through regular a.c. set jobbing channels, notoriously weak in rural areas, Columbia is handling the battery job separately, outlets and advertising.

W Mac Donald

Converting A.C. Sets to D.C., and D.C. to A.C.

Most all-electric models can be changed over, quickly and cheaply, by these fundamental methods

By M. CHERNOW

FOR the past three years I have specialized in the conversion of a.c. sets to d.c. and the adaptation of d.c. models to a.c. This work is much simpler than the uninitiated would suppose, jobs rarely taking more than three-quarters of an hour to complete and frequently much less. Material costs are slight.

Following is a discussion of the fundamental principles involved. These firmly grasped, the experienced serviceman will readily work out the details, which obviously cannot be gone into here due to the many minor differences between various makes and models.

AC to DC

In a.c. chassis, the tube filaments or heaters are generally connected in parallel with their respective supply sources, or transfer secondaries. Transformers, unfortunately, do not function on d.c., so some other provision for lighting the tubes must be made when converting to d.c. operation.

Inasmuch as each tube in an a.c. set draws relatively high filament current it is not practicable to continue to operate them in parallel on d.c. as then the current drain would be the sum of the current required by each individual tube. A converted set would draw something near 1,000 watts! It is quite practical, however, to operate the tubes in series through a suitable resistor for then filament current consumption is limited to approximately the amount of current demanded by one tube.

This is the basic principle of a.c. to d.c. set conversion. Filaments are re-connected in series and are fed directly from the 110 volt, d.c. line through a resistor having a value calculated to drop the filament supply current to approximately that recommended by the tube manufacturers. The proper external series resistance for a string of tubes connected in this manner may be calculated (Ohm's law) by dividing the filament circuit current desired into the

line voltage. Thus in the case of sets using 1.75 ampere tubes 1.75 (the total filament current required) divided into 110 gives 62 ohms as the correct value of external resistance to be used. A matter of a few ohms one way or the other does not materially affect results.

(Editor's Note: The resistance of the tube filaments themselves is not taken into consideration when calculating the value of the external resistor, although this naturally introduces filament voltage error. The author assumes that this error is negligible when compared with that produced by normal line voltage variations.)

The series resistor selected should be sufficiently heavy to pass the filament current required without undue heating. Its power rating can be determined by the formula $P = I^2R$, or in the typical case mentioned above, $1.75 \times 1.75 \times 62$, or 190 watts. Thus it is seen that a resistor capable of dissipating 200 watts, roughly, would be satisfactory.

A.C. receivers may be divided into three main groups for the purpose of outlining conversion methods, classification depending upon the tube types employed.

Group 1, let us say, uses —27's and —24's, with —45's or —47's in the output stage.

Group 2 is equipped with —26's, —27's and —45 or —47 output.

Group 3 has —26's, —27's and —71-A output.

We will now take up each of these fundamental groups, outlining general conversion procedure in each case.

Group 1

The first mentioned group uses 2.5 volt, 1.75 ampere heater type tubes plus output —45's or —47's drawing 1.5 amperes. These may be quickly reconnected in series instead of in parallel by merely clipping out the proper alternate heater supply leads between sockets. An experienced man can do this with very little re-wiring or soldering.

Now, according to our previous calculation a 62 ohm resistor in series with a 110 volt, d.c. line will pass approximately 1.75 amperes to the series filaments and heaters. This, however, causes the output tubes to be overloaded by .25 ampere. But this is easily remedied by connecting a 6 volt, .25 ampere pilot bulb across the filaments of the two output tubes. The pilot, which may of course be used to illuminate the dial, absorbs the overload which would otherwise be applied to the —45's or —47's, thus maintaining equality of current distribution throughout the entire filament circuit.

After the filaments are ready for operation the speaker field is connected directly across the 110 volt d.c. supply line (after the switch) and the plate circuit wiring altered. This is much simpler than it at first seems. The original power transformer and a.c. rectifier tube are discarded but the entire filter system of chokes and condensers retained in its original state. The highest positive potential point in the plate circuit, which is the plate supply lead to the output stage, is connected to the positive side of the line. The original filter system is also connected to this point and inasmuch as the r.f. and detector plates are already connected to the filter output they obtain plate voltage without further attention.

(Editor's note: Inasmuch as the tubes in the majority of modern a.c. chassis are self-biased, IR drop caused by plate current flow through a resistor being utilized for this purpose, 90 per cent of the converted sets handled by the author require no grid-bias adjustment whatever. The tubes apparently adjust themselves to the new plate voltage condition well enough for all practical purposes.)

Figure A, illustrating a typical group 1 conversion, should clear up all doubtful points.

Group 2

In the second group, using —26's, —27's and —45's, we have three different current

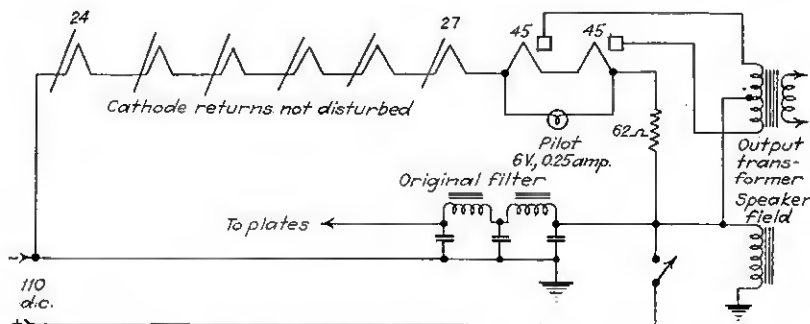

Fig. A—1.75 and 1.5 amp. filaments

drains to contend with in the filament circuit. This complicates matters somewhat. The —26's draw 1.05 amperes, the —27's, 1.75 amperes and the —45's, 1.5 amperes. This assortment of values necessitates the use of parallel resistors across some of the tube filaments in order to equalize current drain.

There are two satisfactory methods of meeting this problem. One is to proceed as in the case of group 1, using the same value of series resistance (62 ohms) and shunting parallel resistors across the —26 filaments to "by-pass" the excess current. The value of such by-passing resistors may be calculated closely enough for all practical purposes by dividing the difference between the current drain of a —26 and a —27 filament ($1.75 - 1.05 = .7$) into the —26 filament voltage, giving $1.5/.7 = 2.1$ ohms as the correct shunt value for the filament of each —26. 2 ohms may be used without materially affecting results.

When several —26's are wired in a series "string" a single resistor having a value equal to the sum of the individual 2 ohm resistors required for, each tube may be bridged across the entire string for convenience of handling with identical results. Thus in the case of four —26's a resistor of 8 ohms across the entire series group as shown in Fig. B would be satis-

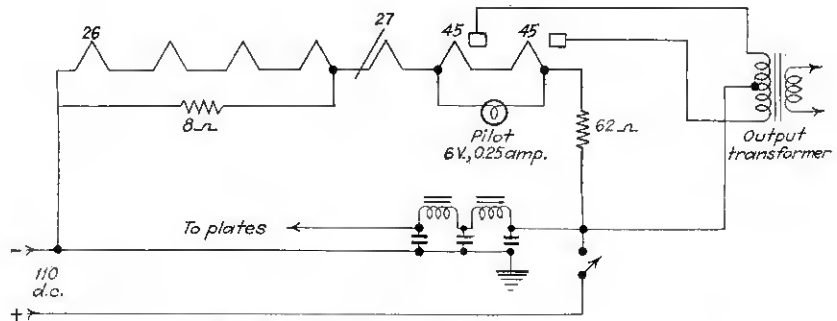

Fig. B—1.05, 1.5 and 1.75 amp. filaments

of the parallel resistor across the output tubes here would be 5 volts/1.5 amperes = 3.3 ohms.

Another way would be to feed the —71-A filaments separately through a second external resistor. And if the owner wishes to improve the set one can easily substitute —45's without any changes in the circuit and then convert the set as in the second group case. This is highly recommended as it improves tone materially and also brings a higher price while labor remains about the same.

Both —45's and —47's work well on the lower voltage of a d.c. line, with barely any noticeable difference in volume in most

d.c. electric sets for a.c. districts. This phase of the game will not, therefore, be gone into in detail except for those conventional circuits utilizing low-current tubes requiring .3 amperes or less of filament current. This includes the old -01-A, —71-A combinations, sets using the new 6.3 volt, .3 ampere automotive type tubes and the 60 milliampere tubes of the —99 and —30 series.

Instead of attempting to re-wire the filaments, or heaters, of such d.c. sets in parallel when converting to a.c. operation, which would necessitate the substitution of heater type tubes, a simple power-pack using two type 82 mercury-vapor rectifiers in parallel is constructed. Such a pack will supply 110 volts of d.c. on which the receiver may be operated satisfactorily. The 82's are rated at 125 milliamperes apiece and if slightly overloaded supply ample current for d.c. sets of the types described. And where type —30 or —99 tubes are used throughout a receiver it is often possible to get by with a single 82.

(Editor's note: The new type 83, which has a 250 milliampere output rating, might also be used in place of parallel 82's and if even greater current values are required it would of course be possible to use 83's in parallel if a husky enough filament transformer could be obtained to light these rectifiers.)

The use of such an easily built power-pack has two advantages. It completely does away with the necessity for receiver circuit alteration and in addition makes the set "universal." By simply equipping the pack with an ordinary 110 volt outlet plug into which the d.c. set's supply cord may be inserted the receiver may be used on either a.c. or d.c.

The total cost of such a powerpack, Fig. E (quoting prices from a mail-order catalog) should not exceed \$3.50, including the pair of 82's. In most cases an old a.c. "B" eliminator can be readily used as a "foundation" by merely adding another socket for the second rectifier. The 82 filaments should be connected in series in such cases as the old "B" eliminators used

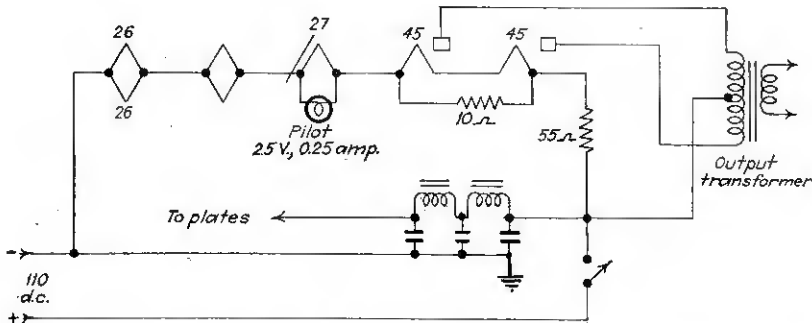

Fig. C—Series-parallel filaments

factory. If there were 5 tubes 10 ohms would be necessary.

The second possible conversion method would be to connect the —26 filaments in parallel pairs, where there are an even number of such tubes in the circuit. As each —26 takes 1.05 amperes, two in parallel would draw approximately 2 amperes, which may be supplied by operating the string in series with a 55 ohm resistor ($110/2 = 55$). To equalize the current drain on the —27 detector the pilot light, which in this case should be a 2.5 volt, .25 ampere type, is connected across its filament to dissipate the excess .25 ampere. The filaments of the output tubes are then "by-passed" with a resistor, calculated by dividing the difference in current drains ($2 - 1.5 = .5$) into the voltage across both output tubes, or 5 volts/.5 amperes = 10 ohms, the correct value for this shunt resistor. Figure C shows such a circuit.

Group 3

The third group is similar to the second in the same manner as the last method ferent current drains. This may be worked in that we have the problem of three described, with the —26's in series-parallel and a resistor across the —71-A output tubes whose filaments are also connected in parallel as shown in Fig. D. The value

cases. In certain sets where only a single audio stage is used after the detector sets do not develop sufficient volume after conversion and it is advisable to substitute pentode output. This obviates the necessity for a second audio stage.

Series condensers should be inserted in both the antenna and ground leads of all a.c. sets converted to d.c. operation. This is important.

DC to AC

A.c. to d.c. conversions constitute about 95 per cent of the existing work and the remaining 5 per cent is the adaptation of

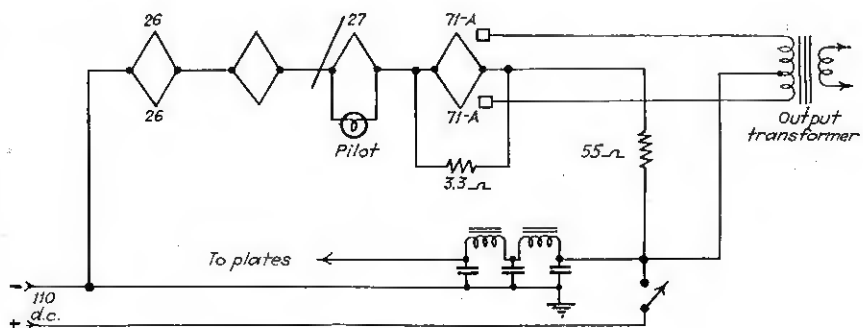

Fig. D—.25, 1.05 and 1.75 amp. filaments

5 volt filament tubes while the 82 works on 2.5. Of course, in the case of the —30 or —99 tube set nothing need be added to the eliminator with the exception of the

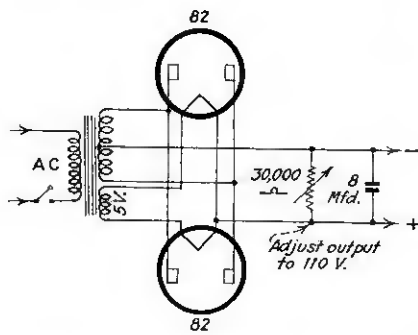

Fig. E—Ac to dc conversion unit

30,000 ohm variable bleeder included to make it possible to adjust supply voltage to exactly 110 d.c. Variations and refinements of this system will occur to experienced shopmen.

Conversions, such as those described are, believe you me, extremely profitable.

Low Reading Ohmmeter

By A. C. Schmitt

A six-volt storage battery may be used in conjunction with an ammeter to measure the lower values of resistance with considerable accuracy due to the ability of such a battery to hold a more or less constant voltage under load. Connect the available ammeter in series with the battery and unknown resistance, calculating for R by means of Ohm's law ($R = \frac{E}{I}$). The battery should be tapped at 2 and 4 volts by means of spring clips gripping the series cell connections.

With a 0-1 ampere instrument it is possible to read from 2 ohms (cell tapped at 2 volts) to 900. A 3 ampere type has a possible range of from $\frac{1}{3}$ ohm to 150. And a 500 milliampere instrument will read from approximately 4 ohms to 1,800.

It is necessary to be careful that the meter is not directly shorted, or driven hard off-scale. One way to guard against this is to include fixed resistance sufficient to safeguard the instrument permanently in the series circuit, subtracting this fixed value each time from the sum obtained by calculation to determine the value of unknown resistance. The meter may, of course, be fused.

Bias Resistor Values

By W. T. Golson

The following table has been found useful in quickly selecting bias resistors suitable for replacement use in a.f. output stages. Resistance values shown are for a single tube and should be halved

when two tubes are employed in push-pull. Wattage rating, on the other hand, should be doubled. It is usually best, I have found, to select resistors having wattage ratings two, or even three, times the specified minimum, especially if they are to be mounted where a good circulation of air is not readily obtained.

TUBE	PLATE VOLT.	RESISTANCE	MIN. WATTAGE
71A	135	1,500	0.5
	180	2,000	1.
45	180	1,500	1.
	250	1,500	2.
10	350	2,000	0.5
	425	2,000	1.
50	400	1,500	5.
	450	1,500	5.
47	250	450	0.6

These approximate resistance values were obtained by applying an ohm's law

$$\left(R = \frac{E}{I} \right) \text{ calculation to data provided}$$

by tube manufacturers. In connection with the type 50, for example, it will be seen that the specified grid bias, 70 volts, divided by plate-current at 400 volts, .055 amperes, equals approximately 1,500 ohms. In the case of the 47, inasmuch as both plate and screen current flow through the bias resistor it was necessary to add these two sums before dividing. Values calculated in this manner are accurate enough for most practical purposes as most set manufacturers apply voltages specified by tube companies. It is of course preferable to use the exact values noted in circuit diagrams if these are available.

Minimum wattage rating is obtainable by applying the power formula: $P = I^2R$, where I is the current in amperes through the resistor and R is its value in ohms. It is, unfortunately, next to impossible to prepare chart figures on tubes used in r.f. circuits inasmuch as r.f. bias resistors usually carry the plate current of several tubes, the number, and hence the drain, varying.

Those Hard-To-Remember New Tubes

29	2.5 volt, 1. amp., a.c. heater double-grid type providing full-wave grid detection, a.v.c. action and a.f. amplification. Contains two cathodes and two grids surrounded by a single plate.	68	6.3 volt, .4 amp., a.c. or d.c. heater type power pentode.
—34	2 volt, .06 amp., d.c. filament variable-mu r.f. pentode.	69	6.3 volt, .3 amp., a.c. or d.c. heater type providing full-wave grid detection, a.v.c. action and a.f. amplification. Contains two cathodes and two grids surrounded by a single plate.
41 (PA)	6.3 volt, .65 amp., a.c. or d.c. heater-type power pentode.	70	6.3 volt, .3 amp., d.c. heater double-grid type providing full-wave grid detection, a.v.c. action and a.f. amplification.
42	6.3 volt, .65 amp., a.c. or d.c. heater-type power pentode.	82	2.5 volt, 3.5 amp. filament full-wave mercury vapor rectifier.
43	2.5 volt, .3 amp., d.c. heater type-power pentode.	83	5 volt, 3. amp. filament heavy-duty full-wave mercury vapor rectifier.
44	6.3 volt, .3 amp., a.c. or d.c. heater-type variable-mu r.f. pentode.	85	6.3 volt, .3 amp., a.c. or d.c. heater type providing full-wave diode detection, a.v.c. action and a.f. amplification. Essentially, two diodes and a triode.
46	2.5 volt, 1.75 (also 1.5) amp., a.c. filament-type double-grid power amplifier for Class A or Class B.	985	5 volt, .5 amp. filament full-wave mercury-vapor rectifier.
49	2 volt, .12 amp., d.c. filament-type double-grid power amplifier for Class A or Class B.	986	5 volt, 1. amp. filament full-wave mercury-vapor rectifier.
52	6.3 volt, .3 amp., d.c. filament-type double-grid power amplifier for Class A or Class B.	89	6.3 volt, .4 amp., a.c. or d.c. heater type triple-grid universal power amplifier. May be used as Class A triode, pentode or Class B triode.
55	2.5 volt, 1. amp., a.c. heater type providing full-wave diode detection, a.v.c. action and a.f. amplification. Essentially, two diodes and a triode.	295 (Triple-Twin)	2.5 volt, 4. amp., a.c. heater type providing detection and a.f. amplification. At once a heater type triode and filament type power amplifier.
56	2.5 volt, 1 amp., a.c. or d.c. heater type general purpose triode.	BR	Gaseous, or cold-cathode, half-wave rectifier.
57	2.5 volt, 1 amp., a.c. or d.c. heater type r.f. tetrode.	GA	5 volt, .25 amp., d.c. filament type power pentode.
58	2.5 volt, 1 amp., a.c. or d.c. heater type variable-mu r.f. tetrode.	LA	6.3 volt, .3 amp., d.c. filament type output pentode.
59	2.5 volt a.c. heater type triple-grid universal output tube. May be used as Class A triode, pentode or Class B triode.	PZH	2.5 volt, 2. amp., a.c. heater type output pentode.
64	6.3 volt, .4 amp., a.c. or d.c. heater type r.f. tetrode.	Wunderlich A & B	2.5 volt, 1. amp., a.c. heater type providing full-wave grid detection, a.v.c. action and a.f. amplification. Contains two grids co-cylindrically arranged around a common cathode plus a plate.
864	1.1 volt, .25 amp., d.c. filament non-microphonic type general purpose triode.	Wunderlich A-Auto & B-Auto	6.3 volt, .4 amp., a.c. or d.c. heater type providing full-wave grid detection, a.v.c. action and a.f. amplification. Contains two grids co-cylindrically arranged around a common cathode plus a plate.
65	6.3 volt, .4 amp., a.c. or d.c. heater type r.f. tetrode.		
67	6.3 volt, .4 amp., a.c. or d.c. heater type general purpose triode.		

New Tube Connections

(Seen from below)

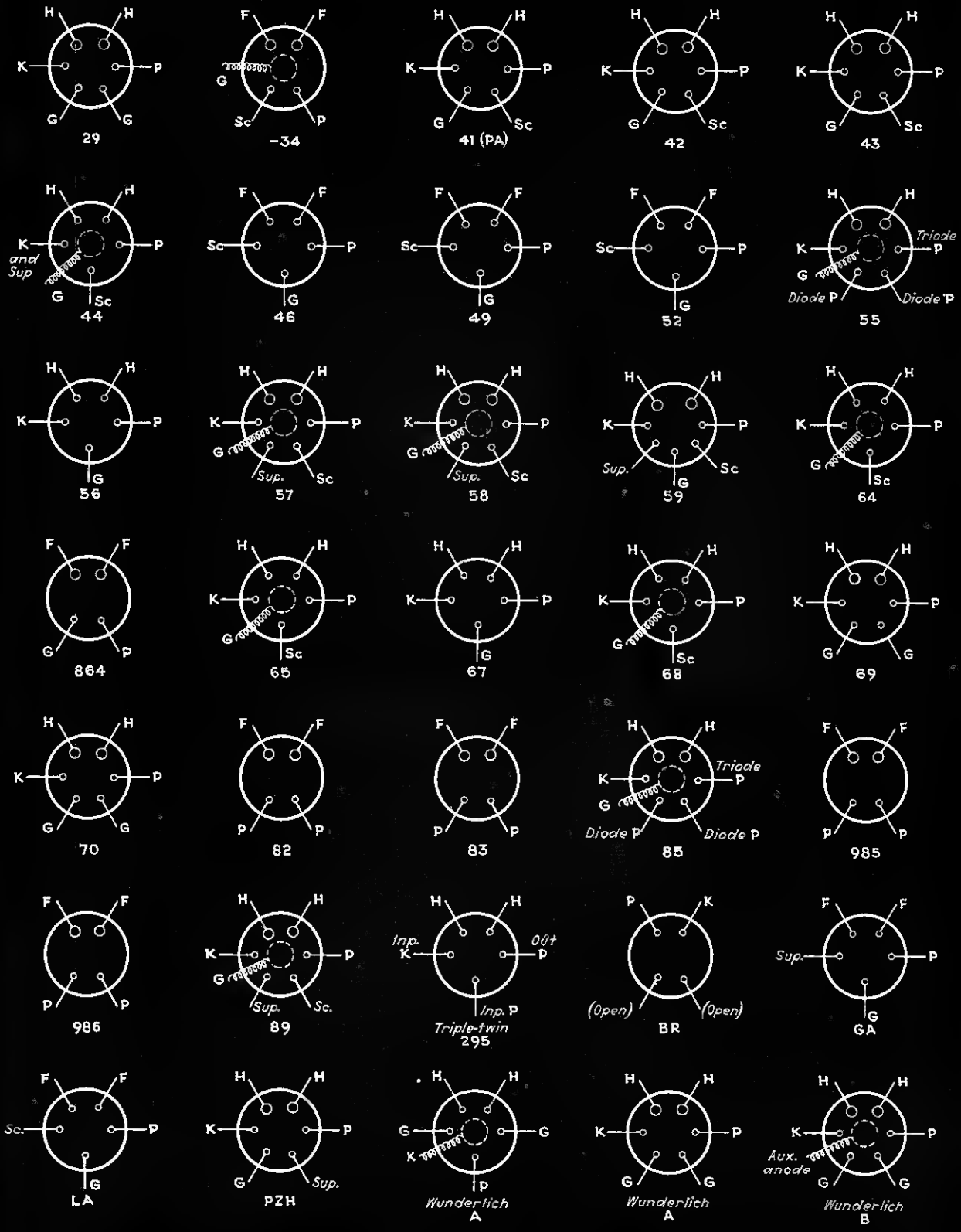

This RADIO RETAILING chart supplements the one which appeared in the February, 1932 issue

NEW MERCHANTISE

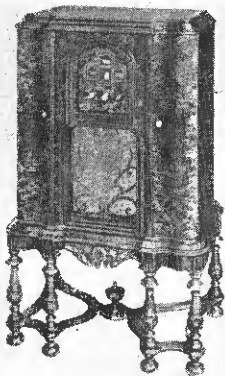

Zenith Model 440

Zenith Line

The 1933 line of the Zenith Radio Corp., 3620 Iron St., Chicago, is made up as follows: 7, 8, 10 and 12 tube midgets and consoles and 7 and 9 tube short and long wave midgets and consoles.

All use the new 7 prong tube, a 2.5 volt, a.c. heater type triple grid universal output tube.

The 7 tube sets are table model Zenette 210, \$49.95, and console model 220, \$62.50.

Zenette model 230, \$55.25; model 240 with twin speakers, \$78.75 and model 245 with twin speakers and automatic tuning, —all are 8 tube jobs. Model 245 is \$102.50.

With the 10 tube chassis, there are Models 410, 411 and 420. Each has shadowgraph tuning to facilitate accurate location of the station, visual tone and volume indicators and two speakers. The list prices are \$105, \$124, \$145, the latter including automatic tuning. Each has Class AAA amplifier using the 7 prong tube.

The 12 tube sets are Models 430 and 440. Both have automatic tuning, shadowgraph tuning, visual tone and volume control,

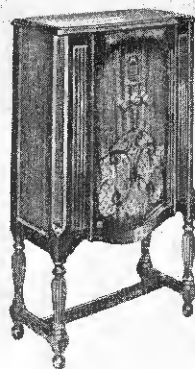

Zenith Model 220

automatic catenary tone-volume compensation, twin speakers, between-station noise suppressor, Class AAA amplifier, and cover from 540 kc. to 1750 kc. They are priced at \$166 and \$184 respectively.

The combination short and long wave receivers are: Models 260 (console) and a table model, each with nine tube chassis. "Spector-type" tuning by means of a moving light dial, simplifies tuning. Range 540 to 18,000 kc. As a console the price is \$92; as a midget, \$73.

The 7 tube standard and long wave sets are a midget type at \$55 and a radio phonograph combination, \$123.50. Range 175 to 2,100 meters.

All prices quoted include tubes and tax. —Radio Retailing, September, 1932.

Fleetwood Radios

The auto-radio receiver which the Fleetwood Radio Co., Fleetwood, Pa., is just bringing out is a six tube superhet using one 36, one 37, three 39's and a 41. The speaker is a dynamic and this set has full range tone control, automatic volume control and can be easily transferred from one car to another.

Fleetwood also makes a line of custom built home sets ranging in price from \$169.50 to \$600. One of the most attractive models is the Governor Winthrop desk set priced at \$169.50 complete with 10 tubes. As a 13 tube job it lists at \$197.50. —Radio Retailing, September, 1932.

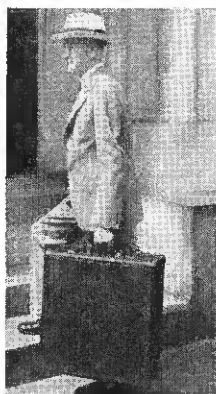

Western Electric Portable P.A. System

A complete public address system which fits into a suitcase so that it can be carried around by hand may be obtained from the Western Electric Co., 50 Church St., New York. It was designed by the Bell Telephone Laboratories and is of the type used so commonly this year by political campaigners.

The entire equipment including case weighs 70 lb. The equipment embraces an amplifier, speaker, control unit and necessary connections. It operates from a.c. To make its convenience complete, it is arranged for use with the lapel mike.

The system can be used with an electrical reproducer to amplify records. The three stage amplifier has a gain of 71 decibels. —Radio Retailing, September, 1932.

Two-Speed Electric Motor

The new Green Flyer two-speed governor controlled electric motor, made by the General Industries Co., of Elyria, Ohio, plays the new 33½ records as well as the 78 r.p.m. type. This motor may be had with 10 or 12 in. turntable, dial and pointer of speed regulator, speed change pointer, speed change escutcheon plate, and automatic stop. It is furnished to use on all voltages and frequencies, as well as for 110 or 210 volt d.c. —Radio Retailing, September, 1932.

S-M Sound Equipment

Silver-Marshall, Inc., 6401 West 65th St., Chicago, has just released specification sheets on its general sound equipment; volume (power level) indicators, Series 60; speakers, "straitline" audio transformers and input control panels, Series 53. —Radio Retailing, September, 1932.



Audiola Model 11300 DN

Audiola Sets

Eight, ten and eleven tube receivers make up the new line of the Audiola Radio Co., 430 S. Green St., Chicago.

Model 11300DN, 11 tubes, has dual Jensen speakers, tone control, automatic volume control, neon tuning light and is housed in a six-legged highboy. \$109.50 complete.

Model 343, 8 tubes including 4 pentodes, has a.v.c. \$56.50.

Model 1050, ten tubes including 6 pentodes; in a lowboy console is \$66.50.

Model 868, 8 tubes, in a six-legged highboy is \$64.50.

Model 1068N, 10 tubes, neon tuning light, is \$77.50.

Models 611 and 1011, both midgets, are 8 and 10 tube models, listing at \$49.50 and \$56.50, respectively. —Radio Retailing, September, 1932.

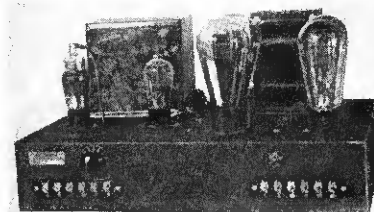

Acratist Power Amplifiers

Two power amplifiers designed for universal input and output impedances are being made by Acratist Products and presented through its distributor, Federated Purchaser, Inc., 25 Park Place, New York.

They can be connected to match mike, phone, radio, 200 ohm or 500 ohm input lines. The output is designed for 9, 15, 500 or 4,000 ohm in the Model 101 and 10 to 15 ohms and 4,000 to 8,000 for the Model 107.

Model 101, a three stage push-pull 250 amplifier, uses one 53, one 56, two 250's and two 281's.

Model 107 is a two stage push-pull to push-pull Class A prime amplifier, using two 57's, two 245's and a 280. —Radio Retailing, September, 1932.

RCA-Victor Microphone

The development of a radically new kind of microphone was recently announced by the laboratories of the RCA-Victor Co., Camden, N. J. Unlike existing mikes which utilize diaphragms, the new "velocity" mike utilizes a sensitive ribbon duralumin. —Radio Retailing, September, 1932.

Wonder Bar Radio and Cellarette

A most novel adaptation of the radio to make it serve an additional purpose is the "Wonder-Bar and Cellarette" just placed upon the market by the Wonder-Bar Radio Co., 6 Great Jones St., New York City.

It combines an unusual piece of furniture with a Philco superhet radio and when opened out to full length (between four and five ft.) offers all the conveniences for dispensing the kind of liquid hospitality that everybody appreciates. Within this console are glass trays for different size glasses, a felt-lined drawer for silverware and a lockable compartment for the beverage bottles.

The tops of the walnut finished cabinet is specially lacquered to make all marks quickly removable.—*Radio Retailing*, September, 1932.



Emerson Radios

Models L-559 (A.C.) and L-459 (D.C.) "Treasure Chest" radio can now be obtained from the Emerson Radio & Phonograph Corp., New York City. The attractively designed chest cabinet is made of selected woods, with hand-carving on top and front, overlaid with four-piece matched walnut veneers. The hinged top acts as a sounding board.

Model L-559 for a.c. operation is a 5-tube t.r.f. set using 2-58's, 1-57, 1-347 and 1-380. \$34.50 complete with tubes and including tax.

Model L-459 d.c. is a 4-tube receiver taking 2-339's, 1-336 and 1-337. The price is the same.

Emerson also makes a midget for a.c. or d.c., \$29.50 and a compact table set for a.c. or d.c., \$27.50.—*Radio Retailing*, September, 1932.

A.P.C. Photoelectric Relay

The A.P.C. photoelectric relay of the American Photoelectric Corp., 215 Third Ave., New York City, has been designed for universal application. It is small, compact and sturdy, and comes complete, ready to plug into the lighting outlet. It employs a standard type photo cell and one standard radio tube and consumes less current than a 40-watt lamp. It has a carrying capacity of 25 watts, non-inductive load. A simple screw adjustment permits its operation at any desired light value, and it may be supplied in normally open-circuit or normally closed-circuit models.

It is furnished for operation from a.c., d.c. or battery. The price of any of these models is \$25 less photocell and amplifier tube which list for \$7.50 and \$1.50 respectively.—*Radio Retailing*, September, 1932.

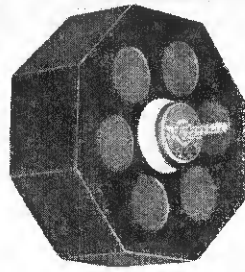
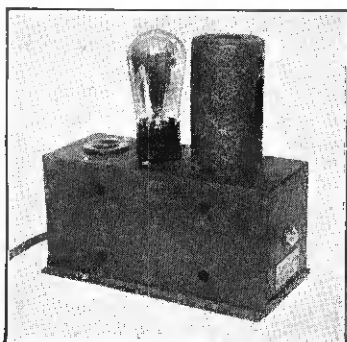

Rola Auto-Radio Speaker

The standard specifications of the new auto-radio speaker placed on the market by the Rola Co., 2570 Superior Ave., Cleveland, Ohio, are, in the small size—over-all diameter 9 in., depth 4 3/8 in., effective cone diameter, 4 1/2 in., net weight 5 lb. 10 oz.

For the large size the dimensions are, in the same order: 9 in., 4 1/2 in., 6 in., and 6 lb. 2 oz.

These speakers come in an octagon-shaped wood case, with single stud mounting.—*Radio Retailing*, September, 1932.

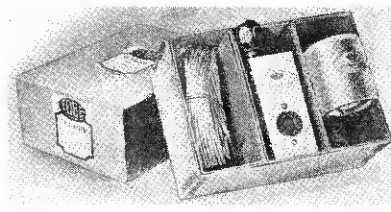

Tobe Filterizer Kit

To keep man-made static out by filtering the power input to the set, providing an aerial outside the field of radio noise and carrying signals to the set through a Filterized lead-in system. Tobe Deutschmann Co., Filterette Div., Canton, Mass., has brought out the "Filterizer Kit."

It contains one antenna Filterette RF-1, 50 ft. of Filterized lead-in wire, and one line Filterette RF-2. The price is \$10.—*Radio Retailing*, September, 1932.

Acme Auto-Radio Sets

Spot-light tuning, Utah speaker, illuminated full vision dial, and automatic volume control are some of the features of the "Moto-Midget" auto-radio of the Acme Mfg. Co., Miamisburg, Ohio. The tubes used are: two 44's, and one each of the 36, 37 and 41 types. All the time needed to install this set, the circular states, is 15 minutes.

Acme also makes a de luxe 6 tube set. The tube line up is the same with the exception of an additional 41. It has all the advantages of the other model such as automatic volume control, etc. In addition it has chromium plated Carter remote control.—*Radio Retailing*, September, 1932.

Reduced Price on American Bosch Auto-Radio

Effective August 19, the list price of the new all-electric American Bosch motor car radio model 100 was reduced to \$85.90, tax paid and including tubes, steering wheel remote control, all wiring accessories, and Magmotor.—*Radio Retailing*, September, 1932.

"Band Spread" Condenser

To assist amateurs in constructing short wave receivers having the much desired band spread tuning characteristic, the Hammarlund Mfg. Co., Inc., 424 W. 33rd Street, New York City, has designed a new type "band spread" midget condenser.—*Radio Retailing*, September, 1932.

New Lynch Products

Five new items designed to bring the benefits of noise-free reception on all wavelengths, have been launched by the Lynch Mfg. Co., 1776 Broadway, New York City. First is an antenna system applicable to both the broadcast and short wave bands. It may be employed with one or several receivers operating from the same aerial.

Among the others are: antenna transposition blocks, a set of ten listing \$2.50; cage antenna spreaders, also sold in kit form, ten to the kit, including the two rugged, end spreaders, \$2.50; antenna insulators designed to meet the rigid requirements of the U. S. Navy, \$3 for a kit of eight insulators, additional individual insulators, 50c; slightly smaller insulators, are priced at \$1.50 for eight, and the all-wave automatic antenna coupler, designed to couple the new antenna systems to any receiver, is \$1.50.—*Radio Retailing*, September, 1932.

Ansley Universal Portable

A new model universal a.c.-d.c. portable radio has just been brought out by the Ansley Radio Laboratory, 147 W. 23rd St., New York City. It is an eight tube super using 3-329's, 2-237's, 2-238's and a 280 rectifier, the latter in the a.c. model only, of course. The speaker is an eight inch Magnavox dynamic. No aerial or ground is required in most locations, a copper screen in the back of the carrying case acting as an antenna. The carrying case, finished in black or brown leatherette, measures 12x16x8 inches and the weight complete is 25 pounds.

The same ingenious plug arrangement incorporated in the previous model is used for changing from a.c. to d.c.

A special model operating on 110 or 220 volts, either a.c. or d.c., is furnished for use abroad.—*Radio Retailing*, September, 1932.

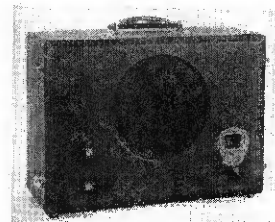

Photoelectric Relay

The "Foto-Switch" photoelectric relay of the G-M Laboratories, Inc., 1735 Belmont Ave., Chicago, embodies an electro-magnetic switch which is opened or closed by the interruption or variation in the illumination on the photoelectric cell. With the "Fotoswitch," any sort of electrical device can be controlled through the medium of a light beam. It is designated as a complete but junior model of the more expensive industrial type relays.—*Radio Retailing*, September, 1932.

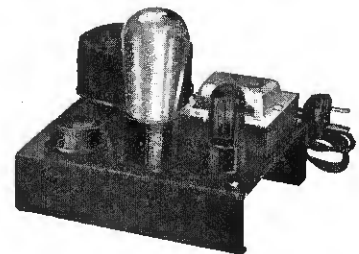

New Sunbeam Products

The latest additions to the line of the Chicago Flexible Shaft Co., Roosevelt Road and Central Ave., Chicago, include the Sunbeam automatic iron "The Ironmaster." It is the same size as the ordinary 6 1/2 lb. electric iron but weighs only 3 1/2 lb. \$8.95.

The Sunbeam "Mixmaster" is a combination food chopper and meat grinder doing both operations with the one attachment. \$5. A can-opener attachment which slips onto the machine in an instant is also available. \$1.25.—*Radio Retailing*, September, 1932.

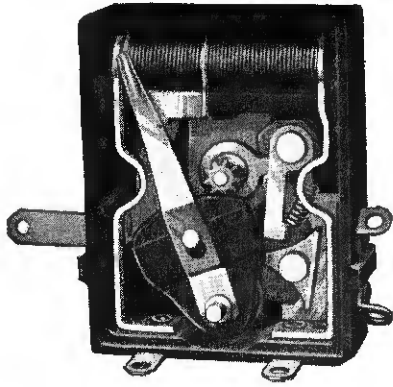

Tapped Bradleyometer

A new tapped Bradleyometer is announced by the Allen-Bradley Company, 1311 S. First St., Milwaukee, Wis., which provides automatic tone correction with volume control.

A single-pole line switch with a rating of 2 amp., 125 volts, can be provided within the Bradleyometer and is operated by the regular control knob.

The new tapped Bradleyometer can be built up to provide any resistance-rotation curve.—*Radio Retailing*, September, 1932.

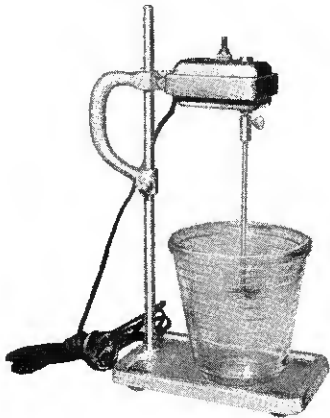

Aldor Mixer and Room Heater

Aldor Corp., 2533 North Ashland Ave., Chicago, Ill., announces an electric mixer that beats eggs, whips cream, makes mayonnaise and mixes light batters, and drinks.

It comes complete, with adjustable stand, six feet of cord, toggle switch and plug. Suggested retail price \$3.95.

Aldor's new room heater and dryer has a small fan installed just back of the nichrome heating element, assuring distribution of heat in all parts of the room at an even temperature.

Finished in assorted colors with cadmium plated trimmings. Suggested retail value of \$4.95.—*Radio Retailing*, September, 1932.

Thayer Coin-Operated Phonograph

A continuous coin-operated phonograph is being made by George R. Thayer Co., Inc., Binghamton, N. Y. The Thayer machine features what they call "Biotone" reception. Greater tone fidelity is said to be produced by having the record in a vertical position so that the needle travels in a straight line, the way the records are made. The pick-up support permits heavy pickup with gentle needle pressure. This machine has full automatic control, plays up to 20 records in consecutive order, replays full load of records indefinitely, is equipped with an anti-overload device, and has volume control.

They are equipped for coin operation, and when this is not desired, a special starting switch is provided so that the machine will play. The cabinet is compact and may be had with solid panel front or glass panel.—*Radio Retailing*, September, 1932.

Telechime

An electrical and musical device, designed to take the place of the door bell in home and commercial signalling systems, has been placed on the market by the General Kontrolar Co., Dayton, Ohio.

Known as Telechime, it has numerous applications and makes a satisfactory supplementary line for the radio dealers. By means of a remote control keyboard it is, in effect, a miniature carillon. Separate push buttons at various stations about the house supply a system for summoning servants, etc. Telechime comes in five standard models and also is provided in custom built combinations.—*Radio Retailing*, September, 1932.

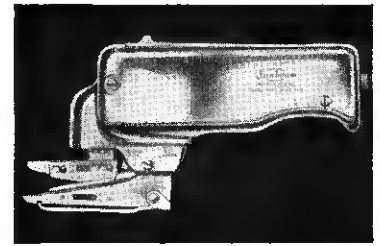

Sunbeam Electric Scissors

To make home dressmaking and a half a dozen other home activities easier, the Chicago Flexible Shaft Co. 5600 Roosevelt Rd., Chicago, has brought out electric scissors. The handpiece is shaped to fit the hands and the blades are placed at a distance where there is no danger of cutting oneself. A generous length of cord permits free movement of the scissors and the blades may be renewed at small cost. Retail price, \$5.—*Radio Retailing*, September, 1932.



"Au-Tenna" Auto Radio Aerial

Four types of automobile radio aeriels are being made by the Consolidated Wire & Associated Corporations, Peoria and Harrison Sts., Chicago, Ill.

No. 1693 is the sedan type in four colors, made in fabric to match all cars. No. 1697 is a special olive drab model for convertible automobiles and touring cars. No. 1695 is a strap type to be mounted from axle to axle. No. 1690 is made for attachment to the rear of the car against or under the tank or any cross member. The list price is \$2 for all models except the sedan type which is \$2.75.

These aeriels cannot be grounded, are covered with a waterproof fabric, are easy to install.—*Radio Retailing*, September, 1932.

Star-Rite "Featherweight" Iron

"Featherweight" the new fast heating, light weight electric automatic iron of the Fitzgerald Mfg. Co., Torrington, Conn., lists at \$6.50. It weighs slightly less than 4 lb. but is full size. It is furnished in lustrous chrome, rust and tarnish proof.—*Radio Retailing*, September, 1932.

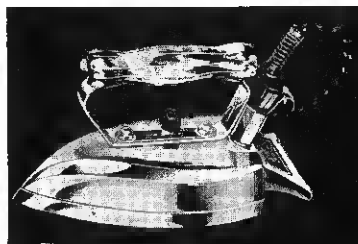

Brush Products

Several new articles for the radio and public address fields are being marketed by the Brush Development Co., 3715 Euclid Ave., Cleveland, Ohio. All of these devices are, of course, operated by the Rochelle Salt Crystal and utilize the Piezo-Electric effect as displayed in this crystal. As they are voltage-operated, they require no field current or polarizing voltage.

Both the P.A.-4 exponential horn unit and P-12 P.A. speaker are driven by four of the regular crystal speaker motors.

The H. F. horn, designed particularly for theatre use, can be connected into present dynamic equipment to reproduce the higher frequencies now being recorded on sound films.

H-85 speaker has been developed for radio sets in dual combination with a dynamic speaker for increasing the range up to eight thousand cycles.

Type B-303 mike can be connected directly into the grid of a tube.—*Radio Retailing*, September, 1932.

Electrad Attenuator Pads

Electrad, Inc., 173 Varick Street, New York City, has brought out a line of L Pad and T Pad attenuators. The list price of the L pad assembly, all sizes is \$3; of the T Pad assembly, all sizes \$5. Both units come in sizes from 15 to 5,000 ohms.—*Radio Retailing*, September, 1932.

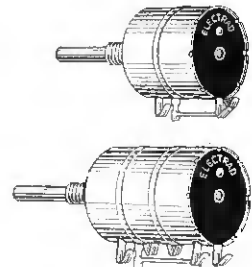

Dubilier Capacitor

Reverting to the handy and economical unit form whereby any desired combination may be assembled for given capacity or KVA requirement, the Dubilier Condenser Corp., 4377 Bronx Blvd., New York City, now introduces its a.c. oil-impregnated, oil-filled capacitors. They are available in working voltages up to 660, and in a wide range of capacities.

Dubilier has developed a new process which results in a more compact, electrolytic condenser. Aside from marked gains in lower leakage current, higher working voltage, quicker comeback time and a more satisfactory power factor, these new condensers possess higher capacity for a given bulk, according to the announcement. The size of the triple and quadruple 8 mfd. units has been cut down to cans one-third smaller than the usual condensers.—*Radio Retailing*, September, 1932.

Bud Auto-Aerial

The new automobile aerial of Bud Radio, Inc., Cleveland, Ohio, has a screen mesh 72 in. long, sewed into a leatherette covering. It is suspended between the axles bringing it as near to the ground as possible, without chance of damaging the aerial. It is installed by placing the webbing around the axle and drawing up tight on the buckle. A heavy coiled spring takes up any slack. \$3.—*Radio Retailing*, September, 1932.

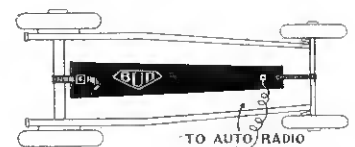



FILTERIZERS

lick your worst enemy

MAN-MADE S·T·A·T·I·C

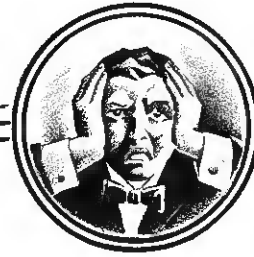
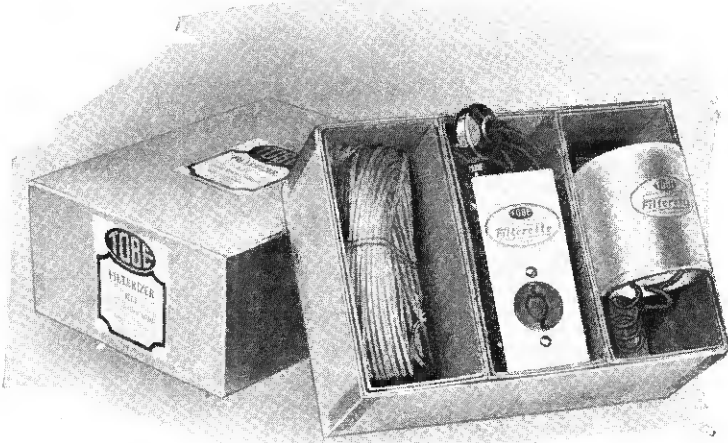

HERE it is! The "something to put on the radio set" that dealers and jobbers have been looking for ever since eruptions of man-made static began spoiling receiver sales.

THE Tobe Filterizer Kit keeps radio noise out of the receiver by the simple method of filtering the power input to the set, providing an aerial outside the field of radio noise, and carrying broadcast signals to the receiver thru a FILTERIZED lead-in system.

TO any receiver—anywhere—add the Tobe Filterizer. The result—instant relief from man-made static.

EVERYONE wants relief from radio noise. The Filterizer provides this relief. Tobe's greatly increased appropriations for consumer advertising give you additional assurance of a tremendous demand for this sensational new development.

DON'T be caught napping. Place your orders today for immediate delivery.

TOBE DEUTSCHMANN CORP.
FILTERETTE DIVISION
CANTON MASS.

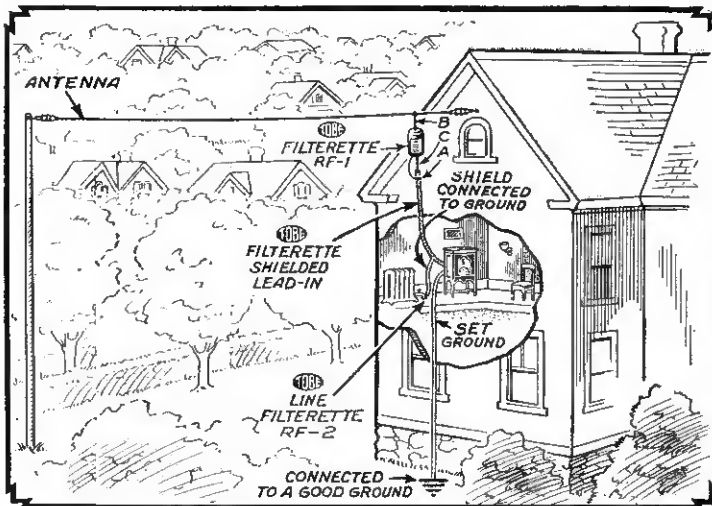

SPECIAL OFFER TO DEALERS AND JOBBERS

Your sample Filterizer kit is now ready at an introductory price of \$4.50. Just attach this coupon to your letterhead with your check or money order, including 25 cents for postage, and we will send one only Filterizer kit, complete with one antenna Filterette RF-1, 50 feet of Filterized lead-in wire, and one line Filterette RF-2. This offer expires September 25th, 1932. After that date Filterizer kits will be available only thru jobbers, at standard discounts from a ten dollar list price.

DISTRIBUTORS: Be ready for the dealer demand for Filterizers. Write today for exclusive territories.

The Acknowledged Authority on Radio interference—Makers of FILTERETTES, the Accepted Remedy

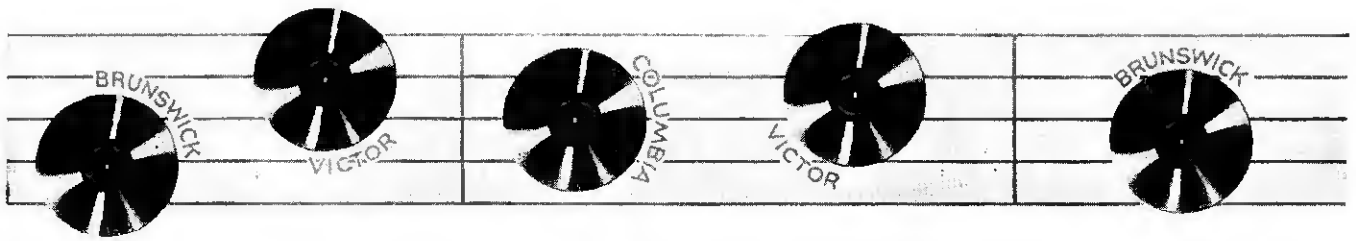

Indian Summer LYRICS

A Review of September Record Releases by Richard Gilbert

THE big three, Brunswick, Columbia and Victor, have met Indian Summer requirements with some extremely salable records, in both the popular and classical categories. Music, apparently, is not suffering as acutely from the ills of depression as other things classified as luxuries. I recall that Harold Samuel; John Charles Thomas, the perennial McCormack; Richard Tauber; Lottie Lehman and the Philadelphia Orchestra turned people away from their 1931-32 concerts. All are conspicuously represented on September's lists. And those thousands who listened to these concerts are your customers today.

The dancing boys and girls haven't renounced the fox trot because of hard times, either. Duke Ellington, Eddie Duchin, Guy Lombardo and Waring's Pennsylvanians still persist in teasing the toes of Young America. Play for these youngsters Ray Noble's scintillating arrangement of *Hold My Hand* (Victor No. 24034)—my selection for the "disc of the month." And watch six bits come across that always expectant counter. That's one example; here are some others—it's a pity we can't list them all:

Columbia

Columbia's classics are substantial items and should engage the interest of all types of music lovers. First in importance is the Masterworks Set of Mozart's lovely *Concerto in E Flat for Violin and Orchestra*. Superbly played by Alfred Dubois and the Brussels Royal Conservatory Orchestra, it is recorded with the utmost clarity and precision. Of hardly less importance—in fact, for many, these discs will constitute the cream of the month—comes Harold Samuel's two disc recording of Bach's *Bartola No. 2 in C Minor* for pianoforte. Samuel's American concerts attract large and enthusiastic audiences. These recordings (Nos. 68056D and 68057D) mirror faithfully the technique of a great performer playing music of undying beauty. . . . Lottie Lehmann, the brilliant German soprano, occasioned all sorts of encomiums from the critics here when she appeared in America last season. Her most recent disc, the *Ocean, Thou Mighty Monster* aria from von Weber's great opera *Oberon* is really a monument of tonal accomplishment (No. G-9055M). . . . You've heard of Richard Tauber before. His latest record is well chosen: two popular Viennese songs in sentimental mood (No. G-9056M), two graceful lyrics telling of springtime and love.

Columbia populars line up well this month. The longer-playing records (standard 78 r.p.m. turntable speed) published by this company are always among the best sellers. The most recent, No. 18006, combines two of the smoothest current tunes: *It Was So Beautiful and I'll Never Be the Same*—ten minutes of delightfully accented and instrumentated dance music at a few cents more than the cost of an ordinary 10-inch disc. Enric Madriguera and his Orchestra make their longer-playing debut, assisted in the second selection by the crooning of the Mullins Sisters. Madriguera, now playing at the Commodore Hotel, is a young Spanish musician who has completely absorbed the national idiom of our popular music; his arrangements are always brilliant and imbued with particular finesse. Another record

by this band you won't want to overlook is *Please Handle With Care* (No. 2690D). . . . On the subject of Columbia long-players: it would be wise to carry a complete stock of these 18000D series discs; other releases are still selling big—make a unit sale of the whole series. . . . Art Kassel and his Kassel's in the Air have two for the younger folks: *Rain, Rain Go Away* and *My Heart's At Ease* (No. 2687D).

Brunswick

Brunswick's lists are bulging over with carefully selected, strongly appealing populars; everyone a cash register ringer.

First, *OK America*, the Winchellesque fete of a potpourri record which begins with a Vic Young overture and progresses through a series of stirring vocalizations by Fran Frey, Carmen Lombardo, the Boswell Sisters, Frank Munn and the ever-sensational Mills Brothers. The selections on disc No. 20112 are all new hits. Feature this effervescent music. . . . Guy Lombardo's *We Just Couldn't Say Good-Bye* (No. 6350) continues this young man's best best-selling series. . . . You've heard of the famous Dorsey Brothers; well, listen carefully to Jimmy Dorsey's saxophone solo, with complete orchestral accompaniment, on No. 6352. It's the same saxophone, incidentally, featured with Red Nichol's original *Five Pennies*. Jimmie's work in *Beebe* and *Oodles of Noodles* will strike terror in the hearts of all aspiring young saxophonists. . . . Earl Hines is a great colored pianist and it is reasonable to expect that his orchestra's versions of *Oh! You Sweet Thing* and *Blue Drag* (No. 6345) would display dazzling keyboard work; they do, and the record mentioned is one of the best. . . . Revivals of old tunes put forth in modern style include, *Down Among the Sheltering Pines* and *Poor Butterfly*, by Isham Jones' Orchestra (No. 6338); *I Never Knew* and *Indiana*, by the Casa Lomas (No. 6337); and, better than ever before, *The Sheik*—Duke Ellington's orchestration would make such modern masters of instrumentation as Maurice Ravel wince with envy (No. 6336). . . . *Three on a Match* and *The Clouds Will Soon Roll By*, played by Anson Weeks and his Orchestra strike the right tempo for enthusiastic dancing (No. 6342). . . . By all means display the Duke Ellington, Cab Calloway and Don Redman numbers; buyers hardly look at the titles of pieces by these amazingly refreshing bands. . . . Likewise, the Arthur Tracey and Bing Crosby discs. The latter crooner has a fine one, *Love Me Tonight*, on No. 6351.

Brunswick's album of vivacious Johann Strauss waltzes—comprising five concert waltz selections played by prominent European symphony orchestras under equally eminent conductors—released in June, found a public evidently. So enthusiastically was this first waltz album received that this company has followed it up with a similar set of five additional Strauss classics. In album No. 37 we find *Wine, Women and Song; Morning Papers; Artist's Life; Songs of Love; Viennese Bonbons*—all worthy successors to the recordings of *Tales from the Vienna Woods, Voices of Spring, Roses from the South, The Blue Danube* and *The* (Please turn to page 48)



Put Columbia Radio-Records where they can be

Seen *and* Sold

WHY keep records on the shelves? Let your customers' eyes work for you. *Display* Columbia radio-records. Proper display is half the sale, as smart merchants know.

This Merchandising Table offered by Columbia places your records where customers can see them and buy them. It holds both ten and twelve inch discs, arranged for quick visibility and ease of selection. The "Merchandiser" is an attractive piece of furniture, worth putting right up in the front of your store to attract attention and produce action.

Columbia supplies these tables to the distributor, who leases them to dealers. Thus there is no profit involved . . . except the profit you make on increased sales!



The Merchandising Table has been enthusiastically received by the trade; Columbia is turning them out as rapidly as possible to meet the demand. Will you place your order now?

COLUMBIA PHONOGRAPH CO., INC.
55 FIFTH AVENUE, NEW YORK, N. Y.

All Trade Marks Reg. U. S. Pat. Off.
M. A. No. Ind. Agnes Nos. 18275 y 18276 de 6 de
Agosto 1930 y 26088 de 73 de Agosto 1929 Marca
Industrial Registrada Mar. Nos. 1696, 2642 y 2677



Columbia

Indian Summer Lyrics

(Continued from page 46)

Emperor Waltz which comprised album No. 36. The reproductions are worthy of the originals and the readings, in the true Viennese manner, charming indeed. An album of delicious music.

Victor

Noble's band is represented by four tunes this month: in addition to a ravishing arrangement of *Hold My Hand*, with thrilling changes in tempo and tonality, there are *Pied Piper of Hamelin*, another nursery rhyme of the current genre (both from the London musical comedy "Hold My Hand"); and a tango fox trot *Good Night Vienna* and *Living in Clover*, FT. (both from the United Artists picture, "Good Night"). Noble's band plays at the New Mayfair in London's foggy capital. The number of the latter coupling is 24064. . . . Other tunes in the smooth manner are: Ruby Newman's Orchestra's *My Silent Love* (one of the really big hits) (No. 24042); *Songs for Sale*, George Olsen and his Music (No. 24070); *Another Night Alone* and *Strange Interlude*, Ruby Newman and his Orchestra (a band of ever-increasing popularity) (No. 24072); and a sweet melody, *It Might Have Been You*, coupled with the present rage—after many months of idolization in Europe—*You're Blasé* by Gus Arnheim and his Orchestra (No. 24054). All are fox trots.

The hit, *You're Blasé*, like *Hold My Hand*, come from England. It is from the musical comedy "Bow Bells." Arnheim does a wonderful job in a slow tempo; insinuating and contagious arrangement, with brilliant trumpets in the foreground. You can't go wrong in suggesting as a starter, *You're Blasé*.

The classics are well represented on all lists. Bach above all the rest, which include Beethoven, von Weber and Mozart. Victor brings forth another Stokowski Bach orchestration: *Chorale Prelude—Auf der Tiefe Rufe Ich* (Out of the Deep I Call to Thee) (No. 7553), an exquisite record of moving music played by the Philadelphia Orchestra at its best. . . . Masterpiece Set No. 123 contains the Old Master's *Concerto for Two Violins in D Minor*. This imported recording of Alma and Arnold Rosé's virtuosic playing, with chamber orchestra, should find a place in every Bach enthusiast's library. . . . The other album set (No. 130) contains John Alden Carpenter's American ballet suite, *Skyscrapers*, music in the modern manner but intelligible to all. Played by the Victor Symphony Orchestra. Also a longer-playing edition at a lower price. . . . McCormack, in his best vein, sings a Hugo Wolf song, *Anacreons Grab* (in German) and an Irish song, *The Bitterness of Love* (No. 1568). . . . John Charles Thomas, whose record of *Trees* (No. 1525) is after fifty-some weeks, still leading the 10-inch Red Seal best sellers, has made what augurs to be a close rival: *Ol' Man River* (from "Show Boat") and the oft called for *Sylvia* (No. 1571). . . . All of the above are exceptionally well recorded and all belong to enduring music.

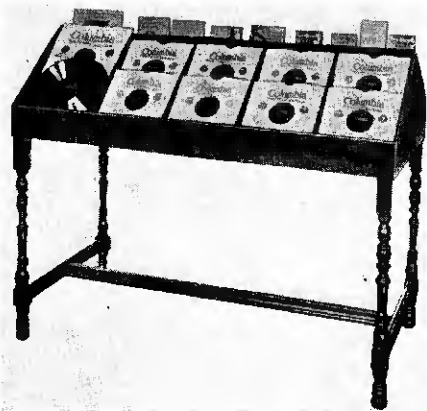

Records Well Displayed are Half Sold

Here is Columbia's record "Merchandiser." This display table holds both the 10 and 12 inch records. It is sold to distributors at cost and leased to dealers, also on a non-profit basis.

WRRAA to Arbitrate Trade Disputes

FROM Milwaukee, noted for its successful socialistic administration of municipal politics, comes another innovation in self-government. The Wisconsin Radio, Refrigeration and Appliance Association announces a new service to its members, and to the industry in general. It has appointed a "council" whose function shall be that of "arbitration, conciliation, adjustment and counseling between dealers, distributors, manufacturers and others interested in radio and electrical appliances," quoting from its bulletin on this subject.

The personnel of the council will be composed of all past presidents of this outstanding radio trade association together with any other persons deemed advisable by the chairman. Representatives selected by the disputants do not have to belong to the Association.

The following are the other articles of this plan:

PURPOSE

To settle in an amicable and satisfactory manner disputes involving credit and trade problems in general, among all branches of the industry that may occur between: manufacturer and distributor; distributor and dealer; dealer and consumer, finance corporations and distributor or dealer or dealer versus dealer.

To eliminate, as far as possible, legal procedure, bankruptcies, assignments, trusteeships, etc., for preservation of assets.

Where liquidation is advisable to dispose of merchandise in an orderly fashion, eliminating widely publicized bankrupt and going out of business sales, which are detrimental to the industry as a whole.

PROCEDURE

Each disputant will select a representative (not an attorney). If there is more than one company interested on any one side of the case it will be necessary for them to agree upon one representative.

Disputants will each have one representative who will select a third party (a member of the advisory council) to act as chairman of the committee.

FUNCTION OF THE COUNCIL

The committee selected, in any given case, will consider facts only and offer impartial recommendations for the fair and logical solution of the matter under consideration. The committee will act only at the request of all interested parties in an advisory capacity between disputants.

Services of the council will not be available when the case involves possible criminal action.

LIABILITY

It must be distinctly understood and agreed that there will be no liability on the part of the association or the council, as a group or individually. Recommendations made are not binding unless approved by all parties.

EXPENSE

The services of the council, the facilities of the association office and the secretaries' time are absolutely free, however any necessary expense such as special auditing, traveling, drawing of special documents, etc., must be borne by disputants.

SIMPLEX is Moving—FAST

Sensational in Performance—Amazing in Price

THE FASTEST MOVING LINE IN AMERICA

AC-DC
Battery

Long and Short Wave

Famous For Its Fine Tone

NEW AND STARTLING VALUES. Long and Short Wave reception without extra cost. Small—compact—portable. Fits snugly into limited quarters. **New Triple Grid and Duplex-Diode Triode Tubes.** New Circuits. Asks no odds in performance.

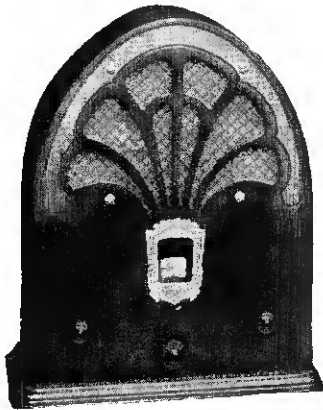

Model P with RCA Tubes **\$29⁹⁵** PLUS TAX
110 or 220 Volt AC 1/55 1/57 1/58 1/47 1/80 Tubes
110 or 220 Volt DC 1/36 2/38 2/39 Tubes
Battery (2 v. Air Cell) 2/32 1/33 2/34 Tubes.

SUPERHETERODYNE FIVE TUBES. LONG AND SHORT WAVE. AUTOMATIC VOLUME CONTROL. Five Tuned Circuits. Sensitivity one microvolt per meter. Never before so fine a Radio at so low a price. Brilliant performance — Deep Full Volume — 10 Kilocycle Selectivity — Extraordinary range—brings in distant stations with unbelievable ease and remarkable clarity. Beautiful cabinets. 9 in. wide, 12 in. high, 6½ in. deep, wt. 13 lbs., packed 16 lbs.

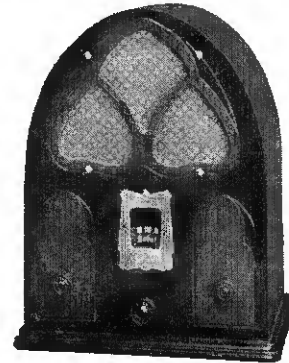

Model R with RCA Tubes **\$19⁹⁵** PLUS TAX
110 or 220 Volt AC 1/57 1/58 1/47 1/80 Tubes
110 or 220 Volt DC 1/36 2/38 1/39 Tubes
This Model not made in Battery Type.

TUNED RADIO FREQUENCY. FOUR TUBES. LONG AND SHORT WAVE. An excellent instrument for local reception but not recommended for great distance or extreme selectivity. 8¾ in. wide, 12 in. high, 6 in. deep, wt. 11 lbs., packed 14 lbs.

For 25-45 Cycle add \$2.50 to List Price

Outstanding Features—Both Models

Long and Short Wave—Two Bands in one.
550-4000 Kilocycles (75-550 Meters).
Simple—Efficient Short Wave Switch.
Tone Control—Static Suppressor.
Built in Antenna (AC)—Phonograph Provision.
Deep, Full Tone at any Volume.

Rugged Ball Bearing Condenser.
Illuminated Dial—Kilocycle Calibration.
Chassis Parts Completely Rust-Proofed.
Self Healing Electrolytic Condenser.
Adequately Shielded Throughout.
Vernier Tuning—Dynamic Speaker.

LICENSED by RCA and
AFFILIATED COMPANIES

The Simplex Radio Co.

Sandusky, O.

Export Dept., 15 Laight St., New York

The Simplex Radio Co., Sandusky, O.
Send literature and prices to
Name
Address



LOOK OUT!

THINGS ARE LOOKING UP!

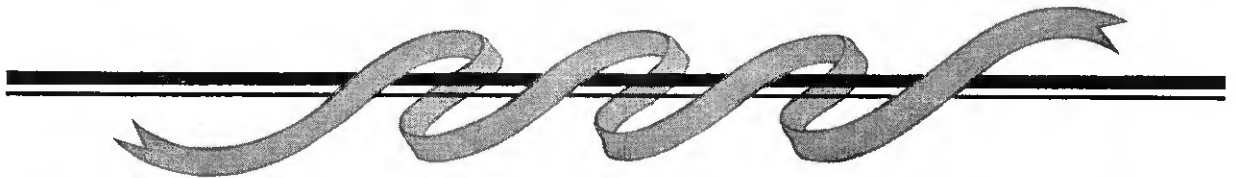

WE HEAR it in the streets. We see it in the news. In the air there is an unmistakable stir of optimism.

America is getting her chin up. People are becoming more than mere-necessity buyers. More than mere bargain buyers. They are shunning sham claims. They are seeking honest values. A change has come.

You are facing, perhaps, the greatest opportunity since the boom of three years ago.

But you are also facing the hardest-to-sell, the most difficult-to-convince customers that business has ever known!

Because the past three years have taught people to spend cautiously. To be exacting, critical.

Conditions are looking up, but they are looking brightest for the dealers who have the most desirable merchandise for sale.

When the buying wave begins in earnest, the greatest rewards will go to the products which enjoy the greatest confidence with the public.

That is why, right now, the General Electric Radio franchise is more valuable than ever before.

Today, General Electric Radio enjoys public confidence, public belief in its tone superiority. Here are the reasons why this is so:

General Electric Radio has not coasted through the depression. All through the lean years it has constantly been made better—in performance, in value. Some of

the greatest advancements in the history of radio have been worked out by G-E engineers during this period. Prices have been lowered to competitive levels.

And every month of these years, General Electric Radio has been kept before the public—advertised. News of the winning of tone-tests, the challenge “Believe your own ears” have proved to millions that General Electric is the best radio made. And millions who have been bargain-burned will want the best now.

So consider carefully the radios you hope to sell them.

The biggest radio months are just ahead of you. If America is about to turn the corner, make sure that *you* turn with her.

GENERAL ELECTRIC RADIO

The G-E Circle—a program of special interest to women—is on the air every week-day (except Saturday) 5.45 P. M. Eastern Daylight Saving Time.



A New Weston Tube-Tester with proven profit-making features



Jewell Pattern 675 Tube-Checker

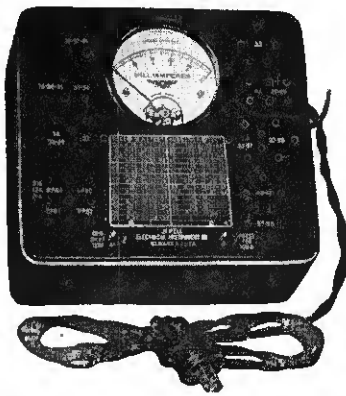

A compact, light-weight tube-checker that is popular for both portable and counter use. Test limits are etched on the instrument panel for quick reference. All present tubes are tested without the use of adapters. Operates entirely from light socket power. Models available for 25 and 60 cycle supplies.

Ask your jobber to show you the Pattern 675 Tube-Checker.

Thousands of radio dealers have found that tube buyers respond quickly to the tube testing service made possible by Weston and Jewell Instruments.

Now set owners appreciate this service and buy with confidence from dealers adequately equipped.

Weston Model 677

The new Weston Model 677 Tube-Tester makes the exclusive features of Weston-Jewell design available at a cost so low no dealer can afford to be inadequately equipped.

Such proven features as the **direct reading three-color tube performance meter**, **zero-reset test circuit**, **line voltage indicator**, and **compensating control** are combined in the Model 677 with compact design and Weston high standards of workmanship.

Performance tests are provided by the Model 677 for all current types of tubes. Internal tube shorts of even high resistance are indicated by Neon lamps. Spare sockets are built in the test panel to be used for future tubes that may be developed.

Ask your jobber to show you one of these new Tube-Testers!

WESTON-JEWELL

Weston Electrical Instrument Corp.] 581 Frelinghuysen Ave.
Jewell Electrical Instrument Co.] Newark, N. J.

Please send me your complete catalog W-J of radio panel and radio service instruments.

Name

Address

★

★ *H*ysteria
is *H*istory now

YOU can thank the Columbia Phonograph Company for pointing out the road to reason in the radio business. Perhaps you remember how Columbia sounded a call to sanity last spring. The frenzied days of the radio industry were over, but the old methods of production and distribution persisted. It was necessary to make a fresh start—to hand out a new deal all around. Columbia, under its own leadership, created sensible new policies to meet the conditions—and, what is more important, *carried them through*.

As a result, Columbia is today in a sound and enviable position. It is not forced into mass production; sets are turned out only to *meet the demand*. It is not forcing its distributors and dealers into mass consumption; they need only carry as many sets as they can *sell profitably*. Because the old high-pressure methods have no place in Columbia's policies, the evils of overloading,

distress merchandise, and price-cutting are eliminated.

A gratifying number of distributors throughout the country have signed up with Columbia. They and their dealers both are enthusiastic about the new Columbia radios—well-designed, up-to-the-minute instruments, backed by almost a half century of musical experience. And they are equally enthusiastic about the new Columbia merchandising and advertising plans, which reflect the sound, reasonable spirit behind everything Columbia is doing.

You who are seeking a first-rate line of radios, with a progressive, independent organization behind them—you who want definite opportunities for profit today and in the future—are invited to write for further information to the Columbia Phonograph Company, Inc., 55 Fifth Avenue, New York City.

FROM AN INTERESTING EXPERIMENT *to*



A SUBSTANTIAL RAPIDLY GROWING BUSINESS

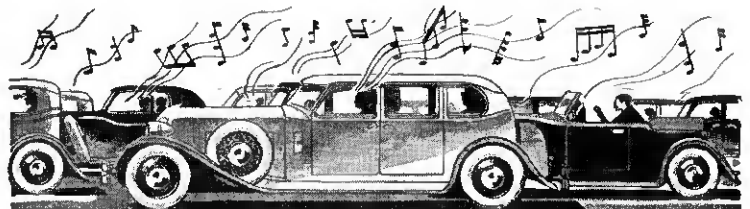

. . . and MALLORY is responsible for this development in Automobile Radio

When Mallory engineers developed the Mallory-Elkon "B" Eliminator and the Mallory-Elkonode they contributed two of the really outstanding achievements in the automobile field. But they did *more*—they helped, more than any individual or any organization had ever helped before, in *bringing into being a great, profitable business of unlimited possibilities and immediate opportunities.*

Now any motorist can enjoy all-electric automobile radio—and every dealer can *sell it at a profit!* For the Mallory "B" Eliminator, that makes automobile radio *all-electric*, is *approved for all the leading radio sets.*

Here is an immediate market, a big market, a rapidly growing market and one that offers *your full margin of profit on every sale.* No dealer in automobile radio is asked to take a loss on a trade-in set—and most of the sales he makes *make others!*

List Price **\$19.95**
Complete including relay and cable... nothing else to buy.



The Tried and Proven Mallory-Elkonode is the heart of the Mallory-Elkon "B" Eliminator. No rotary parts, nothing to wear out and no fear of setting up interference. Over 20,000 Mallory units are in service and giving satisfactory performance.

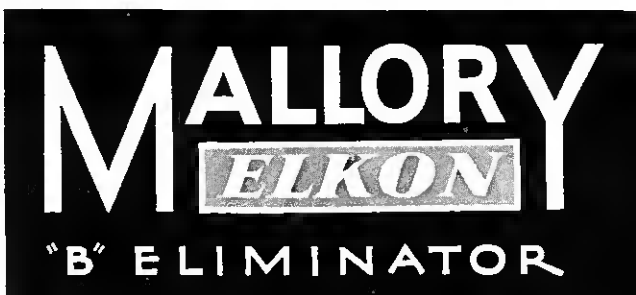

P. R. MALLORY & CO., Incorporated, INDIANAPOLIS, INDIANA

EVIDENCE!

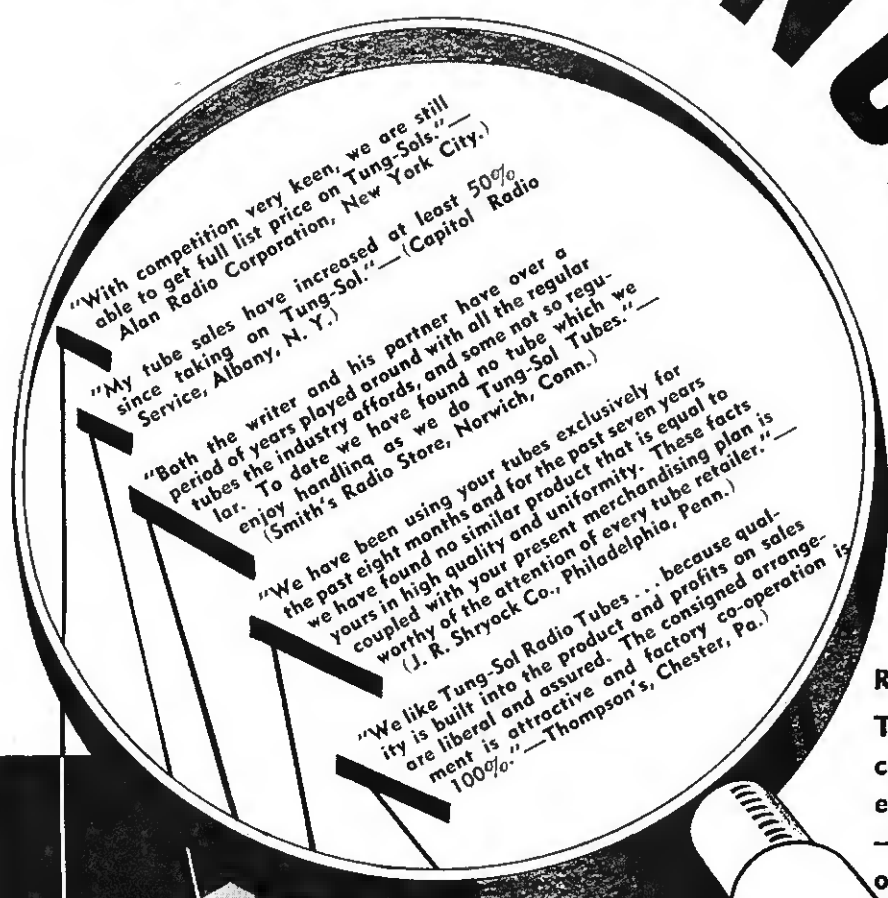

"With competition very keen, we are still able to get full list price on Tung-Sols." — Alan Radio Corporation, New York City.)

"My tube sales have increased at least 50% since taking on Tung-Sol." — (Capitol Radio Service, Albany, N. Y.)

"Both the writer and his partner have over a period of years played around with all the regular tubes the industry affords, and some not so regular. To date we have found no tube which we enjoy handling as we do Tung-Sol Tubes." — (Smith's Radio Store, Norwich, Conn.)

"We have been using your tubes exclusively for the past eight months and for the past seven years we have found no similar product that is equal to yours in high quality and uniformity. These facts coupled with your present merchandising plan is worthy of the attention of every tube retailer." — (J. R. Shryock Co., Philadelphia, Penn.)

"We like Tung-Sol Radio Tubes ... because quality is built into the product and profits on sales are liberal and assured. The consigned arrangement is attractive and factory co-operation is 100%." — Thompson's, Chester, Pa.)

READ THE EVIDENCE!

These unsolicited letters from successful Tung-Sol dealers—selected at random from dozens on file—tell their own story. The quality of Tung-Sol radio tubes and the Tung-Sol merchandising plan operate together to produce increasing repeat business with uniform, full profits. Why not look into the Tung-Sol proposition yourself? For complete details write

Licensed under patents of Radio Corporation of America



TUNG-SOL
RADIO TUBES INC.
 NEWARK, NEW JERSEY

- Atlanta
- Baltimore
- Boston
- Charlotte
- Chicago
- Cleveland
- Dallas
- Detroit
- Kansas City
- Los Angeles
- New York
- St. Paul

IF YOU KNEW—

HOWARD'S "LOW PRICE FOR FINEST QUALITY RADIO" and all the Howard DIRECT TO DEALER features you would realize, in a minute, that Howard stands out head and shoulders, giving you the opportunity to get a larger share of the really profitable radio sales.

The Howard dealer has these advantages: Substantial saving through buying direct—undeniable quality—tonal superiority—beautiful and acoustically correct cabinets—every new and approved technical feature including Duplex Automatic Control (embracing Noise Eliminator and Full Automatic Volume Control)—new tubes and additional features assuring greater selectivity and greater power sensitivity.

Remember, Howard has had 12 years of successful experience in making quality receivers, only. It bears a GOOD NAME.

It will pay you to send for our new, illustrated descriptive literature and direct-to-selected dealers sales plan.

HOWARD RADIO COMPANY

Factory and General Offices: South Haven, Michigan

Export Address:

Ad. Auriema, Inc.

116 Broad Street

New York City

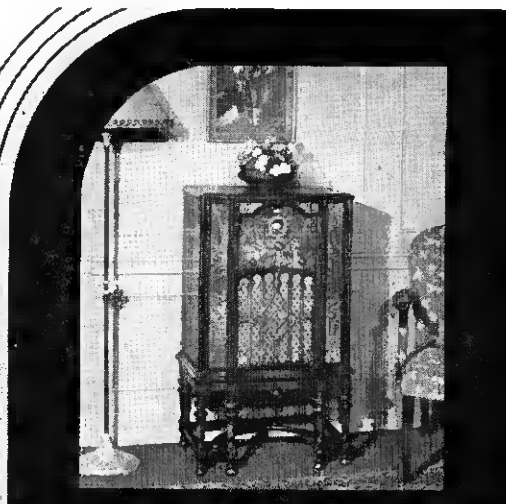

MODEL "K"—10 TUBES

LARGE chassis employing one Radio and one Intermediate frequency amplifying stage. Contains the Howard Duplex Control featuring Automatic Silent Tuning and Full Automatic Volume Control. Image frequency suppresser. Walnut Veneered cabinet: Height 41 in.; width 25 in.; depth 16 in. Tubes employed: 3 type 58 new, 4 type 56 new, 2 type 47 Pentode, 1 type 80 Rectifier.

List Price—\$80.50. Tax Paid.

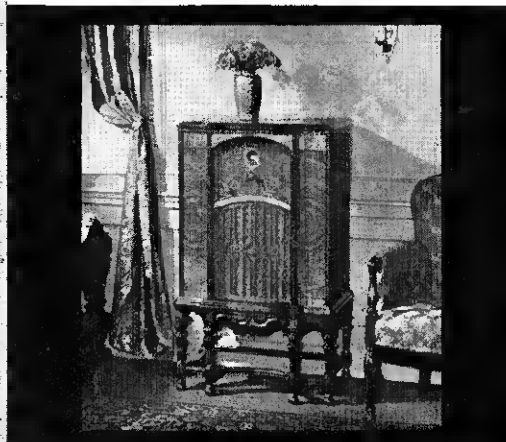

MODEL "L"—11 TUBES

EXTRA large chassis. Contains the Howard Duplex Control featuring Automatic Silent Tuning and Full Automatic Volume Control. Beautiful Walnut cabinet: Height 43 1/2 in.; width 27 in.; depth 16 in.

Tubes employed: 3—56, 1—57, 4—58, 2—42, 1—80.

List Price—\$100.50. Tax Paid.



MODEL "M"—13 TUBES

DELUXE chassis, 24 in. wide. One Radio and two Intermediate amplifier stages. Push-pull driver stage to feed type 45 "push-push" power amplifiers. Howard Duplex Control embracing Automatic Silent Tuning and Full Automatic Volume Control. Exquisite Walnut cabinet: Height 44 1/2 in.; width 30 in.; depth 19 in.

Tubes employed: 4—58, 6—56, 2—46, 1—82.

All new tubes including Push-Push and Mercury Vapor.

List Price—\$139.50. Tax Paid.



MODEL "501"—DELUXE—20 TUBES

MAMMOTH chassis and separate Power Unit employing 20 tubes. Special Giant Auditorium Speaker handles complete volume range of this powerful receiver, with reserve to spare. This marvelous instrument possesses every new feature, including many that are exclusive with Howard. Cabinet of exquisite beauty. Height 40 1/2 in. Width 37 1/4 in. Depth 19 3/4 in.

List Price—\$395.00. Tax Paid.

Order a set of the NEW Centralab Motor Radio Suppressors today

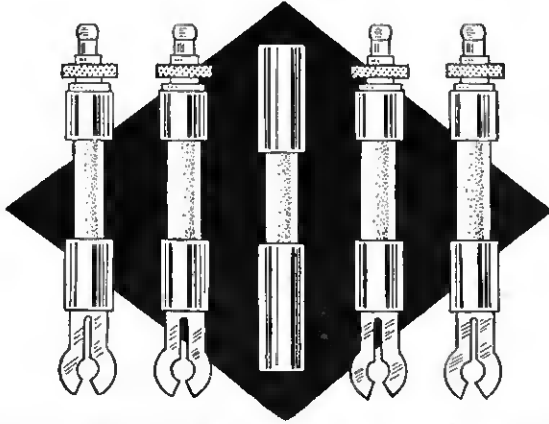

for the NEW Centralab Suppressors are actually 50% to 500% more efficient in reducing spark noise than the average suppressor.

The generous 1½ in. of resistance material is baked at a temperature of 2700 degrees with its ceramic jacket; both together forming a solid granite-like unit. Simplicity itself!

And this very simplicity makes possible an unusually LOW price. Order a set today. One for each spark plug plus one for the distributor.

	Retail Price	Your Price
Set of 5 for 4 cyl. car	\$2.00	\$1.10
Set of 7 for 6 cyl. car	2.50	1.50
Set of 9 for 8 cyl. car	3.50	1.90

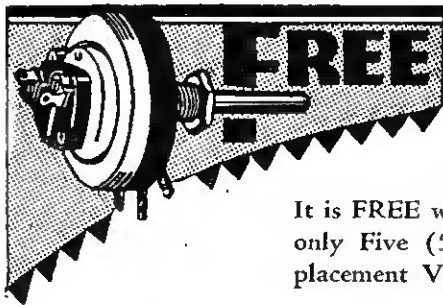

50c Volume Control Guide with additional "dope" is just off the press.

It is FREE with your order of only Five (5) Centralab Replacement Volume Controls.

10 Centralab Fixed Resistors

Packed in a neat, convenient service carton (your own choice of resistance values) listing at \$3.00 and a new QUICK REFERENCE WALL CHART, showing resistance combinations at a glance . . . all for only \$1.75.

Centralab

CENTRAL RADIO LABORATORIES
Milwaukee, Wis.

LYNCH

Noise-Reducing Antenna Products Solve the Interference Problem!



practically noise-free results on all waves, long and short alike. For the broadcast listener, the short wave and television experimenter and the "amateur." Ideal for suburbs as well as the most congested city areas. Very simple to "hook-up" to any receiver. Better performance assured.

(A) **LYNCH Transposition Blocks**
Extremely durable. Made of "Lynchite," a new material, recognized for its great resistance and natural freedom from electrical losses.
Handy Complete Kit of 10 Blocks..... \$2.50

(B) **LYNCH Cages-Aerial Spreaders**
Great pick-up qualities and freedom from directional effect. Also made of "Lynchite." **Kit of 10**..... \$2.50

(C) **LYNCH "U. S. Navy Standard" Antenna Insulators**
Prevent electrical loss or leakage across the antenna insulators. Also made of Lynchite.
Kit of 8..... \$3.00

(D) **LYNCH Commercial Antenna Insulators**
Patterned after the "U. S." but for use where the tensile strength of the "U. S." is not required.
Kit of 8..... \$1.50

(E) **LYNCH "All-wave" Antenna Coupler**
Secures best possible results with any of the Lynch noise reducing antenna systems. \$1.50

LYNCH METALLIZED Resistors



1, 2, 3 Watts

Now— Moisture Proof!

Not affected by atmospheric conditions.

Pigtails molded in; easy to solder. Greater overload capacity; noiseless; guaranteed dependable.

Also LYNCH Precision Wire Wound Resistors—Rating 1 watt; tolerance 1%.

Jobbers: Write for Special Folder and Confidential Discount Sheet on these new LYNCH Antenna Products.

Dealers and Servicemen: Discount of 40% from above List Prices. Send order TODAY or write for free Color Code Card, and new Illustrated, descriptive folder.

LYNCH MFG. CO., Inc., 1775R Broadway, New York City

NEW AUTO RADIO

\$16⁹⁵

COMPLETE

Sell, install Auto Radios at price that beats all competition. Make double ordinary profits. 5 latest auto type Tubes, Dynamic Speaker. Covers 195-550 meters (adjustable to 175 meter Police Calls). Range of 100-1000 miles. Steering column control, illuminated dial, key switch, 39" flexible shaft. Small size, 5 x 7 x 7". Mounts anywhere with universal bracket. Has range, selectivity, tone of sets selling for 4 times as much.

EVERYTHING FURNISHED

R.C.A. licensed first quality tubes; Remote Steering Column Control; Dynamic Speaker; Steel-Shielded Connecting Cables; Ignition Spark Suppressors; Antenna—everything except "B" Batteries, with simple instructions for installing.

BIG PROFIT FOR DEALERS

Order demonstrator sample today. Send \$2.00 deposit with letterhead showing that you are a dealer. Pay balance C.O.D. plus 2% Federal Tax. Be sure to specify number of cylinders. No orders filled except to dealers. SPECIAL QUANTITY PRICES ON REQUEST.

MY OWN RADIO, Inc., Dept. 112, 1800 Grace St., Chicago, Ill.

Only Reliable Products
can be continuously
advertised

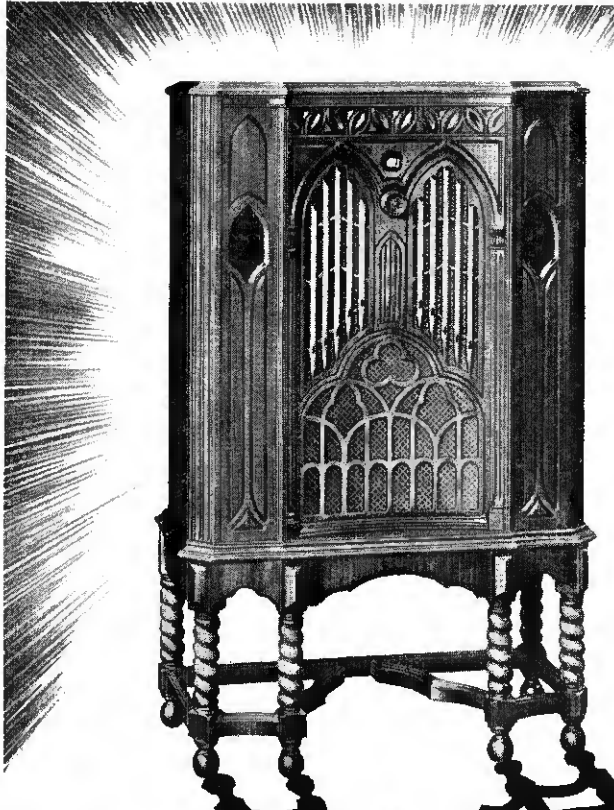

Majestic Model 307
 Eleven-tube superheterodyne receiver provides Synchro-Silent Tuning, Tone Control, Duo-Diode Detection, Automatic Volume Control, new Visual-Lite tuning dial, full-pentode amplification, new resistance-coupled push-pull power output, and mercury-vapor rectification. Price, complete with Majestic tubes (federal tax paid), **\$89.50**

Within the last three weeks—at distributor and dealer meetings in Atlantic City, Chicago, and other key centers from coast to coast, the new Majestic line has been received with an enthusiasm beyond anything we have seen since we brought out our first great models in 1928. They tell us it is the finest, the most appealing line from a selling standpoint this company has ever produced.

With production facilities making possible attractive discounts and exceptional trade-in offers—even on a line that can outsell competition purely on price and merit—Majestic presents the outstanding opportunity of 1932-33. Prices quoted are for sets completely equipped with Majestic tubes—*federal tax paid*. It will pay you to write or wire your nearest Majestic distributor NOW.

GRIGSBY-GRUNOW COMPANY, CHICAGO,
 and affiliates, with factories at Chicago; Toronto; Bridgeport; Oakland; London, England; and Sao Paulo, Brazil
 Manufacturers also of MAJESTIC REFRIGERATORS



MODEL 324
 12 tubes . . . twin speakers, **\$149.50**

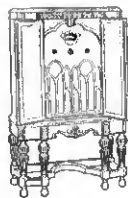

MODEL 304
 11 tubes . . . twin speakers, **\$99.50**



MODEL 314
 7 tubes . . . twin speakers, **\$69.50**



MODEL 294
 12 tubes, long and shortwave, **\$99.50**



MODEL 293
 9 tubes . . . full-pentode amplification, **\$73.00**

and now
Majestic eclipses even its greatest previous achievements

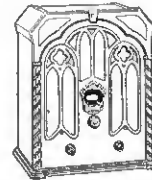

MODEL 311
 7 tubes . . . full-pentode amplification . . **\$44.50**

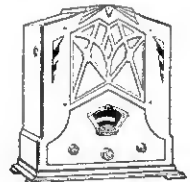

MODEL 291
 9 tubes . . . full-pentode amplification . . . **\$62.50**

Majestic radio sets are licensed under patents and applications of K. C. A., Hazeltine, La Tour, Lowell & Dunmore, and Boonton Research Corporation.

Prices slightly higher on West Coast.

Majestic
RADIO SUPERHETERODYNE

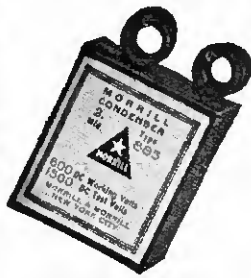

2 MFD—600 Volts—
Size: 2" x 1 1/8" x 7/8"

MORRILL & MORRILL
30 CHURCH STREET NEW YORK CITY
Sole U. S. A. Distributors of the Siemens & Halske
condensers and resistors.

—NEW!

MORRILL Uncased Condensers

Especially compact. A product of outstanding quality. The ultimate in reliability. Send for circular E-1.

NEW AUTO Radio AERIAL AND SUN VISORS COMBINED

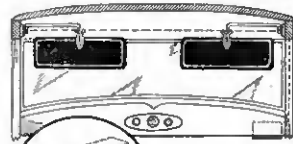

VIZOR-TENA gives a perfect auto radio aerial in a pair of sun visors... highest grade, 4-way adjustable sun visors and aerial all in one. Aerial feature gives clear, undistorted reception surpassing any now in use. Easily, quickly installed.



No Tearing Up Auto Top
SAVES 1/3 in cost and work over roof-type aerial. Thousands installing auto radios—BIG DEMAND for this simple, efficient and economical, radio aerial and sun visor.

Ball and Socket hinge — easily, quickly adjusted, either to side or front, or up or down.

Write Quick for detailed information. Retail \$5.00 per pair. To Dealers \$3.00 F.O.B. less 2%. Get this PROFIT MAKER NOW.

VIZOR-TENA CO., 210 Balcony Bldg., Kansas City, Mo.



Portrait of Horace Being Masterful

LIFE in a radio shop is so full of little emergencies, isn't it? Now take the case of Horace, who, in the portrait above, is facing an emergency. At the other end of Horace's phone is Mrs. Quigley who reports that Saturday night some one knocked her radio set off the table and broke all the tubes. Will Horace send a service man out with a set of new tubes? Of course Horace will, but will Mrs. Quigley first tell Horace the kinds of tubes that go into her set? No, Mrs. Quigley can't tell Horace what kinds of tubes go into her set—all she knows is that it's a Model X Blasto. Very well, Horace will send out Joe, the service man, with the tubes. But how, you ask, will Horace find out what tubes go into Mrs. Quigley's Blasto without Joe making an extra trip out to the Quigleys just to look at the set? Sounds like a poser, doesn't it? But not to the redoubtable Horace. Deftly he will pick up the October "Annual Specifications Number" of *Radio Retailing*, turn to the listing on the Blasto receivers and in his suavest Adolphe Menjou manner give Joe the tube numbers for the Quigley set.

CUSTOMERS, too, have the habit of asking annoying questions about radio set prices, cabinet styles, range in meters and kinds of tubes used. Let them go ahead and ask. Every radio dealer and distributor who subscribes to *Radio Retailing* will get the whole dope on 1932-1933 broadcast receivers, radio phonograph combinations, shortwave sets and auto radios in the October "Annual Specifications Number" of *Radio Retailing*, just as these readers have received similar data on other years' models in October 1931, 1930, 1929, etc. Naturally, the 23,000 readers of this premier radio business magazine will refer to the October issue many times in the next twelve months. Naturally, too, astute radio set, tube and accessory and side-line manufacturers are taking advantage of the unusual reader interest and long life of this October "Specifications Number" of *Radio Retailing* to publish in it the complete sales story of their home entertainment merchandise and appliances.

Radio Retailing

A McGraw-Hill Publication
330 West 42d Street, New York, N. Y.

"I BELIEVE THAT NO MANUFACTURER HAS EVER BUILT MORE INTO A RADIO RECEIVER OR TAKEN MORE OUT OF THE PRICE THAN FADA RADIO HAS THIS YEAR."

J. Q. D. Anderson

FADA RADIO FEATURES PROVIDE WHAT "YOU DESIRE TO SELL" IN A MODERN RADIO

- SUPER-HETERODYNE CIRCUIT
- NEW POWERFUL 2½ VOLT TUBES
- AUTOMATIC FLASHOGRAPH
- TUNING SILENCER
- FLOATING SPEAKER BAFFLE
- TEN KILOCYCLE SELECTIVITY
- FLOATING GANG CONDENSERS
- SUPERLATIVE TONE QUALITY
- AUTOMATIC NOISE ELIMINATOR
- ILLUMINATED STATION RECORDER
- DUAL FUNCTION DIODE DETECTOR]
- TRIPLE AUTOMATIC VOLUME CONTROL
- MULTIPLE ACTION DYNAMIC SPEAKER
- TONE FILTER AND NOISE ELIMINATOR

\$52⁵⁰ to \$142⁰⁰

INCLUDING TUBES AND TAX

Model 87

Nine Tube Super-Heterodyne. New Triple Grid and Push Pull Power Pentode Tubes. Complete with tubes and Excise Tax.

\$73⁰⁰

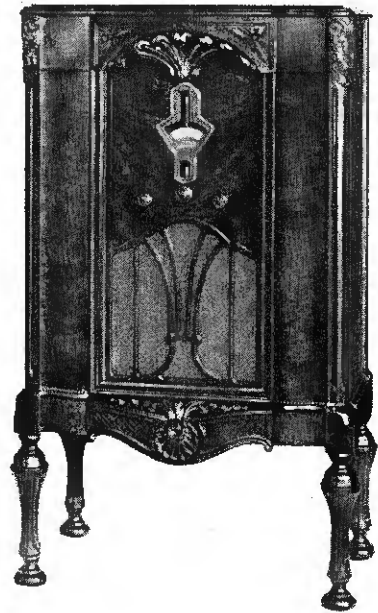

FADA RADIO and ELECTRIC CORPORATION

ORCHARD and QUEEN STS.—LONG ISLAND CITY, NEW YORK

FADA
Radio

EVERYWHERE...

Crowds Acclaim Noiseless Radio

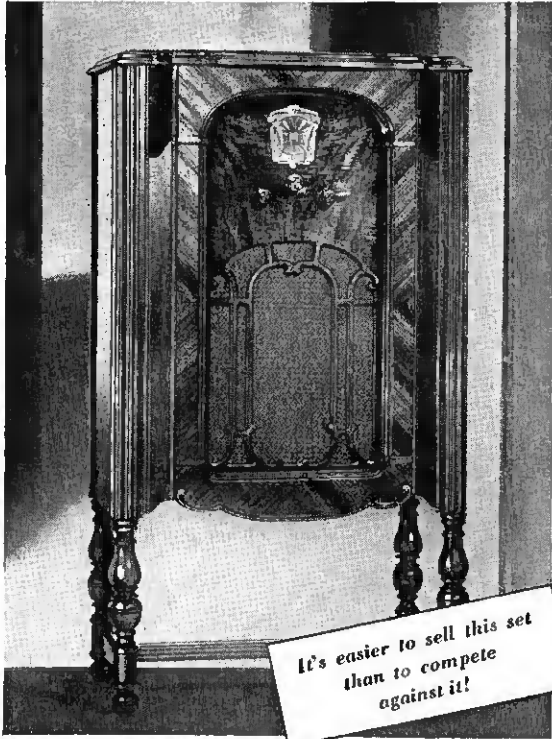

Model K-120 — Completely shielded 8-tube console superheterodyne. Automatic volume control. Latest type radiotrons; R. F. and A. F. Pentodes. Phonograph pickup connection. Outlet for Kolster 3-tube short wave converter. Full 8-inch dynamic speaker. Cabinet, 41 inches high, carries cross fire butt walnut panel, zebra wood top and bottom rails and pilasters. Price (with Radiotrons), \$76.50.

Ask for a copy of this book. Completely describes the Kolster Rejectostatic System. Gives details of installation. Valuable!



LISTENERS MARVEL AT KOLSTER PERFORMING PERFECTLY IN PRESENCE OF STATIC CREATORS THAT "KILL" ORDINARY SETS

"Kolster HAS something this year." That is the voiced opinion of the crowds that are witnessing Kolster demonstrations everywhere. That is the cryptic five-word statement that echoes throughout the world of radio today and that sums up the tremendous possibilities that the new Kolster line presents.

For Kolster has taken the crackling, the sputtering, the buzzing, the clicking out of radio and put an entirely new brand of performance in.

Kolster has produced a radio that laughs at household static creators... that goes on performing without interference and without loss of tone quality in spite of vacuum cleaners, oil burners, hair dryers and a host of other electrical appliances that ruin reception on the ordinary set.

The new Kolster International Rejectostatic Radio is the radio sensation of the year. It has given every dealer the long-sought-for "something to talk about" to put power behind his salesmanship.

For information concerning the new Kolster line, open territories, dealer franchises, etc., write or wire today. And remember... "Kolster HAS something this year."

KOLSTER RADIO INC.

Kolster Radio Inc. is affiliated with Mackay Radio and Telegraph Company and other units of the International System
 New York Office: International Telephone and Telegraph Building
 67 Broad Street, New York City

Factory: 360 Thomas Street, Newark, New Jersey

KOLSTER INTERNATIONAL

REJECTOSTATIC RADIO

Pat. Pending

The Radio Sensation of The Year

Change DC to AC with

JANETTE ROTARY CONVERTERS

For Farms—Ships—City
Apartments—Automobiles

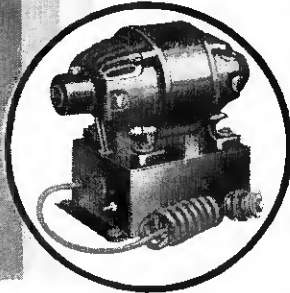

Wherever the current supply is DC, use JANETTE Rotary Converters to operate your AC receivers.

JANETTE Converters are filtered to give radio results as good as, or better than, that obtained with central station AC. Built to outlast the radio set.

Available in 15 sizes. Capacities from 20 to 2500 watts. Input voltages of 6, 12, 32, 115 or 230 volts. Standard machines deliver 110 volts, 60 cycles AC.

MAIL COUPON FOR DETAILS

JANETTE MFG. CO.
555 W. Monroe St.,
Chicago, Ill.

Gentlemen: Please send prices and details on your:

- Rotary Converters
- Auto-B-Power (B-eliminator for auto-radio)
- Gas Engine Generators

Name

Address

City State

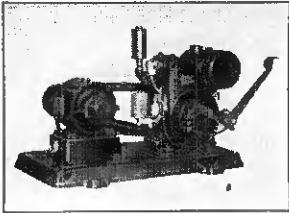

Above: Gas engine-operated JANETTE 110-volt, 60-cycle generator. Capacities: 300/300 watts. Ideal for sound-trucks.

HAVE YOU SEEN THE OHMITE "HEAT TEST"?

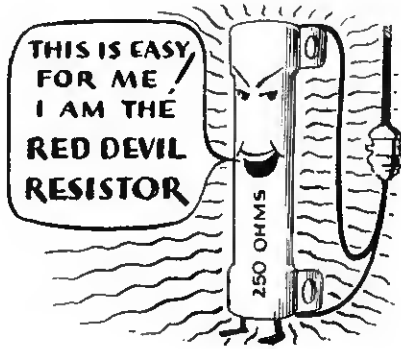

Almost any jobber can show you the Heat Test in which the TEN Watt Red Devil Resistor dissipates FIFTY Watts continuously without failing, even though it becomes red hot under this tremendous overload—positive proof that here is a resistor capable of withstanding much abuse.

Use these dependable wire-wound REPLACEMENT RESISTORS in your service work and be free from expensive "return calls." Red Devils are no larger and cost very little more than carbons and may be had in values from 1 ohm up to 100,000 ohms. Use the coupon below for Bulletin No. 10, an interesting folder giving full details. There's no obligation.

OHMITE MANUFACTURING CO.

633 N. Albany Ave.
Chicago, Ill.

Ohmite Mfg. Company 633 N. Albany Ave., Chicago, Ill.
Please send me your Replacement Resistor Bulletin No. 10.
Name
Address
City

SEARCHLIGHT SECTION

POSITION WANTED

RADIO service man—10 years' experience building and servicing sets. Married. Member of The I. of R.S.M. and Official Service Mens Assoc., graduate R.C.A. Inst. Desires position. Best of references. PW-172, Radio Retailing 330 West 42d St., New York City.

SALESMEN WANTED

BRAND new opportunity for salesmen with cars call on radio dealers, service men and jobbers. Popular low-priced specialty every service man needs and wants. Men now making \$25 to \$40 weekly as sideline. Write today. Give details and territory you can cover. SW-164, Radio Retailing, 330 West 42d St., New York.

SALES representative with knowledge of the radio market. An opportunity to earn \$60.00 to \$75.00 a week during a campaign on a special low price "deal" premium feature. Also possibility of a permanent connection with manufacturer of over twenty-five years standing and enjoying a national reputation. Apply at once giving complete business record, references and age. SW-171, Radio Retailing 330 West 42d St., New York City.

TO HANDLE high grade line of replacement transformers for radio trade. State territory covered and lines handled. General Transformer Corp., 1900 N. Kilbourn Ave., Chicago.

SALESMEN—calling on radio and automotive dealers to sell the new outstanding auto receiver the Fleetwood. Write giving details and territory you can cover. Fleetwood Radio Company, Fleetwood, Pa.

REPAIRING

GUARANTEED microphone repairs—any make or model—24-hour service. Stretched diaphragm double button repairs \$7.50. Others \$3.00. Single button repairs \$1.50. Write for 1932 catalog with diagrams. Universal Microphone Co. Ltd., Inglewood, Calif.

HUGE SAVINGS IN USED PUBLIC ADDRESS EQUIPMENT

Send for bargain lists. Motion Picture and Sound Systems.

SALES ON SOUND CORP.

Dept. RR. 1000 Broadway, New York

VACUUM CLEANER

REPAIR PARTS

Write quick for free illustrated folder and new, low price list. Parts for all cleaners! Renewed cleaners guaranteed for 1 year! 24-hour service rewinding armatures. Write today!

RE-NEW SWEEPER CO.

2262 Gratiot Ave. Detroit, Michigan

SERVICEMEN-DEALERS

Complete Stock of NEW Radio Replacement Parts

Write for our Catalogue

Hard to Get Parts—We have them. Send us your repair work for estimate.

GRANT RADIO LABORATORIES

6521-R South Halsted St. Chicago, Ill.

DEALERS—ATTENTION

Rock-Bottom Prices on Household Appliances Nationally Advertised

Write Today—Folder Free

TRIANGLE APPLIANCE CO.

3786 Kendall Ave., Detroit, Mich.

SPECIAL NOTICE:

To the Radio Industry

Advertising in connection with legitimate offers of surplus stocks and discontinued models of radio merchandise is acceptable in this section of "Radio Retailing."

Extreme care will be exercised by the publishers to prevent the use of advertising in the Searchlight Section to encourage price cutting on current models of merchandise or equipment. Nor will advertising which invites violation of the dealer's contract with the manufacturer be acceptable.

All merchandise offered in the Searchlight Section must be accurately and fully described and must be available on order.

DEALERS—SERVICEMEN

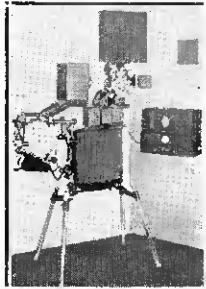

Get into the Talking Picture Business. Install and Service Sound Equipment! Wholesale prices on Projectors, Sound on Film, Amplifiers, Phonographs, Microphones, etc.

Write at Once.

Mellaphone Corp.

Rochester, N. Y.

The BAR of MUSIC

The newest adaptation of the radio to serve an additional purpose . . . supplementing mental entertainment with bodily refreshment.

The WONDER BAR

AND CELLARETTE

AS A BAR
AND RADIO
COMBINED

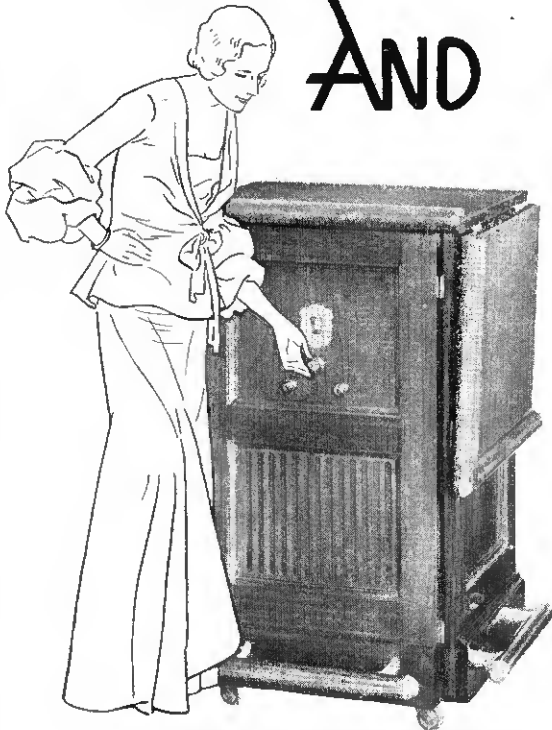
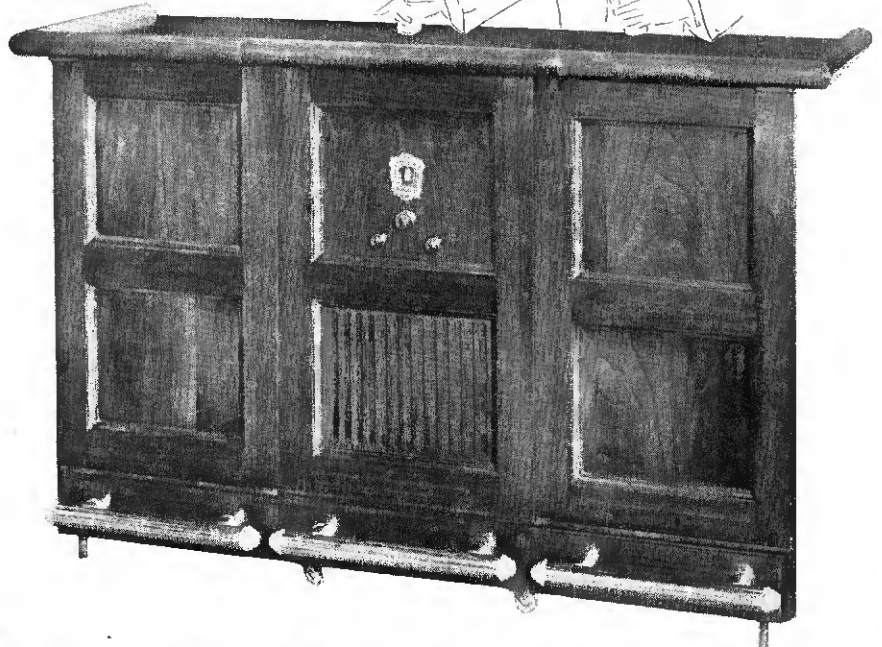

AS A RADIO & CELLARETTE COMBINED

DEALERS—WIRE AND WRITE AT ONCE
FOR PARTICULARS AND SAMPLES

Pending the appointment of a
distributor in your territory
WE WILL SHIP YOU DIRECT

WONDER BAR RADIO CO.
6-8-10 GREAT JONES STREET
NEW YORK CITY

COMPLETE WITH

PHILCO SUPERHETERODYNE RADIO

when closed is a radio in regular console size, whose interior contains facilities for serving popular refreshment and whose top can be used as a resting-place for tray and glasses—the marks of which can be easily wiped off, thanks to special lacquering process. The radio is the famous Philco, whose many exclusive features assure perfect tone, full volume and extreme sensitivity and selectivity . . .

Open up the sides and you have a Wonder-Bar, between four and five feet long, beside which you can lounge with appropriate comfort and listen to your favorite programs. Behind are several glass trays for different size glasses, a felt-lined drawer for silverware, and a lockable compartment that provides ample storage for beverage bottles. The ensemble is finished in walnut, and combines an unusual piece of furniture, a first-class musical instrument, and the conveniences for dispensing welcome hospitality. At its attractive list price the Wonder-Bar's appeal to the public is assured.

DISTRIBUTORS IN ALL PARTS OF THE COUNTRY
desiring to handle this easy-selling
proposition and to derive the full benefit
of introducing it in virgin territory
WIRE AND WRITE AT ONCE FOR PARTICULARS
AND SAMPLES

Radio Servicemen: get into Public Address



Public Address is the latest offspring of radio and is fast outgrowing its parent. Today it is an immense industry — an invaluable aid in many lines of endeavor.

Public Address has tremendous possibilities — its applications are almost unlimited. It offers a vast new field of profits for the enterprising serviceman.

Public Address is today recognized as a powerful advertising medium which produces results. Merchants everywhere are alive to the possibilities of Public Address and are anxious to tie up with it.

The radio dealer and the radio serviceman are the logical ones to develop the use of Public Address. There are no difficult technical problems to overcome because modern sound equipment is extremely efficient and simple to operate. Prices, too, have been popularized.

Public Address will play an important part in pre-election campaigns this Fall. P. A. systems are used in theatres, dance-halls, skating rinks, swimming pools, churches, mortuaries, airports, racetracks, stadiums,

schools, hospitals and in many other places. How many of these are there in your city? Why not canvass them systematically at once?

Fourteen pages of the September number of **RADIO BARGAIN NEWS** are devoted to *Public Address*. Everything from microphone springs to a complete 15 watt output P. A. system is included. We are distributors of the justly famous *Universal Microphones* and carry a complete stock, from the popular Model X listing at \$10.00 to the new Bullet Type LL shown in the illustration above, listing at \$100.*



We build "ACRATONE" Amplifiers, from the single 245 developing 3 watts to the DeLuxe 250 Push-Pull with an output of 15 watts. Hundreds of other items, too numerous to list here, are featured in **RADIO BARGAIN NEWS** at prices which are lowest in radio history.

Get into this lucrative field. Send for your copy of our catalog and assemble your demonstrator P. A. system without delay.

**Universal Microphones* carry a dealer's discount of 40% and 2% for cash.

Federated Purchaser Inc.

25 PARK PLACE

NEW YORK, N. Y.

The Following Distributing Units Maintained for Your Convenience:

JAMAICA, L. I.

MT. VERNON, N. Y.

NEWARK, N. J.

92-26 Merrick Road

31 East 3rd Street

273 Central Avenue

PHILADELPHIA

ATLANTA, GA.

2909 Broad Street

631 Spring Street, N.W.

Fill in and mail this coupon back to our main office at once for a Free copy of Radio Bargain News.

Name

Address

City..... State.....

*
Freed-Eisemann
LOW PRICED MIDGETS AND CHASSES
An important message to
DEPARTMENT STORES, CHAIN STORES, and JOBBERS

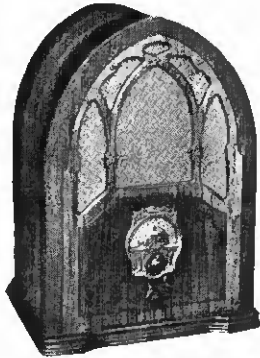

5-tube A.C. Set; Walnut Veneer and gum Table Model. Pentode output; all circuits completely shielded; spot light tuning scale with slow motion drive, compensated tone circuit. Latest type 2 1/2 v. tubes.
List price—**\$31.50**
with tubes, tax included.
Also built for D.C. operation.

Freed-Eisemann Radio Chasses and Midgets are now being manufactured by Freed Television & Radio Corporation. The same standard of high quality known and recognized in the Freed-Eisemann products is found in the new line of apparatus we are proud to announce.

DEPARTMENT STORES, CHAIN STORES

We are in a position to supply you with Freed-Eisemann Midgets and Radio Chasses, 5, 7, and 9 tube, superheterodyne models, at really competitive prices. Quality, design and performance compare very favorably with the finest radio sets made. These models can be furnished with the Freed-Eisemann trade mark, or with your own private brand trade mark. Write us for details on our department and chain store proposition.

JOBBERS

We have a very interesting proposition for Jobbers to sell Freed-Eisemann Radio Sets and Chasses to smaller dealers, particularly in rural sections. The Freed-Eisemann name is a well-known one to consumers and dealers. We shall be very glad to send you details of our new products.

Licensed under R.C.A. patents.

5-tube A.C. Set; Walnut Veneer and gum Treasure Chest with hand-carved overlays; illuminated dial with slow motion drive; tone control; pentode output. Latest type 2 1/2 v. tubes.

List price—**\$42**

with tubes, tax included.

Also built for D.C. operation.



FREED TELEVISION & RADIO CORPORATION

ARTHUR FREED, President
*Trade Mark Reg. U. S. Pat. Off.

22-17 41st Avenue

Long Island City, N. Y.

CONTENTS for SEPTEMBER, 1932

Copyright, 1932, by McGraw-Hill Publishing Company, Inc.

<i>On a Silver Platter</i>by O. H. Caldwell	17
<i>I Demonstrate the Difference</i>says R. G. Seeli	18
<i>Action!</i>	21
<i>A Plan for the RMA</i>	22
<i>Meiklejohn's Men</i>	24
<i>Tubes on Consignment</i>	26
<i>Watch Your Replacement Business This Year</i>	27
<i>Oil Heat</i> by R. V. Suttcliffe	28
<i>Shake Hands With Your Partner</i> by Tom F. Blackburn	30
<i>Now Is the Time</i>by Lloyd Jacquet	32
<i>News of the Month</i>	34
<i>The Detector</i>	37
<i>Converting AC Sets to DC and DC Sets to AC</i> by M. Chernov	38
<i>Service Shortcuts</i>	40
<i>New Tube Connections</i>	41
<i>New Merchandise</i>	42
<i>Indian Summer Lyrics</i>by Richard Gilbert	46
<i>WRRRA to Arbitrate Trade Disputes</i>	48

INDEX TO ADVERTISERS

This index is published as a convenience to the reader. Every care is taken to make it accurate, but *Radio Retailing* assumes no responsibility for errors or omissions

Page	Page
American Weekly..... 15	Stewart-Warner Corp..... 11
Arcturus Radio Tube Co..... 9	Stromberg-Carlson Tel. Mfg. Co. 2
Atwater-Kent Mfg. Co..... 4-5	L. Tatro Prod. Corp..... 14
Central Radio Lab's..... 56	Transformer Corp. Inside Front Cover
Columbia Phonograph Co..... 47-52	Tung-Sol Radio Tubes, Inc..... 54
Crosley Radio Corporation, Inside Back Cover	United American Bosch Corp.... 1
Cunningham, Inc., E. T. Back Cover	United States Radio & Television Corp. 16
Deutschmann Corp., Tope..... 45	Vizor-Tena Co..... 58
Fada Radio & Television Co..... 59	Weston Elec. Instr. Corp..... 51
Freed Television & Radio Corp.. 64	Zenith Radio Corporation..... 12-13
General Electric Co..... 50	
Grigsby Grunow Co..... 57	■
Howard Radio Co..... 55	SEARCHLIGHT
Hygrade-Sylvania Corp..... 3	SECTION
Janette Mfg. Co..... 61	<i>Classified Advertising</i>
Jewell Elec. Instr. Co..... 51	Classification
Kolster Radio Co..... 60	Page
Lynch, Arthur H..... 56	AGENTS WANTED 61
Mallory Co., P. R..... 10-53	POSITIONS WANTED..... 61
Morrill & Morrill..... 58	REPRESENT. WANTED..... 61
My Own Radio Co..... 56	REPAIRING 61
National Carbon Co..... Front Cover	SALESMEN WANTED..... 61
Ohio Carbon Co..... 8	RADIO STOCKS
Ohmite Co..... 61	Federated Purchaser, Inc..... 63
RCA Victor Co., Inc..... 6-7	Grant Radio Laboratories..... 61
Simplex Radio Co..... 49	Mellaphone Corp..... 61
	Re-New Sweeper Co..... 61
	Sales on Sound Corp..... 61
	Triangle Appliance Co..... 61
	Wonder Bar Radio Co..... 62

McGraw-Hill Publishing Company, Inc., 330 West 42d Street, New York, N. Y. Branch offices: 520 North Michigan Ave., Chicago; 383 Mission St., San Francisco; Aldwych House, Aldwych, London, W. C. 2; Washington: Philadelphia; Cleveland; Detroit; St. Louis; Boston; Greenville, S. C.; Los Angeles. James H. McGraw, Chairman of the Board; Malcolm Muir, President; James H. McGraw, Jr., Vice-President and Treasurer; Mason Britton, Vice-President; Edgar Kobak, Vice-President; H. C. Parmelee, Vice-President and Editorial Director; Harold W. McGraw, Vice-President; C. H. Thompson, Secretary.

Member A.B.P. Member A.B.C. Printed in U. S. A.

CROSLEY

9 Tube Superheterodynes



The
Crosley
MAYOR

This 9-tube superheterodyne employs Class "B" amplification using Mercury Vapor Tube—static control—the new 2½-volt heater type tubes—tuned circuit suppressor pre-selector—automatic volume control—meter tuning—continuous (stepless) tone control—illuminated hairline dial with vernier drive—normal audio level control—full floating moving coil dynamic speaker. A real radio value. Dimensions: 17½ inches high, 16¾ inches wide, 9¾ inches deep.

\$55.00
Complete with Tubes
Tax Paid



The Crosley **CONGRESSMAN**

A 9-tube superheterodyne chest model with dual dynamic speakers, one at each end. The front panel is walnut overlay on a background of walnut veneer. The mottled edged top is of walnut veneer and is hand rubbed. The chassis is the same as is used in the Crosley MAYOR. Sells at a sensationally low price. Dimensions: 11 inches high, 25½ inches wide, 11 inches deep.

\$59.95
Complete with Tubes
Tax Paid

The Crosley **SENATOR**

This handsome 9-tube superheterodyne console model has a slant walnut overlaid front panel arched with tool maple. The cabinets are of walnut veneer and capped with cross-matched straight grained walnut veneer. Same chassis as the Crosley MAYOR. Dimensions: 30 inches high, 27½ inches wide, 12½ inches deep.



\$65.00
Complete with Tubes
Tax Paid

The Crosley **LEGISLATOR**

This 9-tube superheterodyne console model uses the same chassis as the Crosley MAYOR. The magnificently beautiful cabinet is of the choicest veneers and finest woods. The sensitivity and selectivity of this receiver is remarkable and worthy of the highest praise. Dual dynamic speakers. Dimensions: 45½ inches high, 26 inches wide, 14 inches deep.



\$75.00
Complete with Tubes
Tax Paid

with Full Class "B" Amplification using Mercury Vapor Tube...are **SENSATIONAL RADIO VALUES!**

CROSLEY values are now greater than ever before with the new 9-tube superheterodynes incorporating Class "B" amplification with Mercury Vapor Tube, at prices that are sensationally low. This entirely new feature makes possible tremendous undistorted volume and eliminates overloading at high power peaks and affords astonishingly superior radio performance. Other radio refinements such as static control, automatic volume control, meter tuning and full dynamic speakers make these 9-tube superheterodynes the greatest values in radio today. The prices at which these radio marvels sell are amazingly low and suit the economy of the times. See your Crosley Distributor to learn more about these remarkable 9-tube superheterodynes and others of the fast-selling Crosley line.

CROSLEY Electric REFRIGERATORS



Model C-35
2½ cu. ft. NET Capacity. 7 sq. ft. Shelf Area. Dimensions: 22" high, 21½" wide, 29" deep. **\$89.50** F. O. B. Factories Tax Extra



Model C-45
4½ cu. ft. NET Capacity. 9 sq. ft. Shelf Area. Dimensions: 28½" high, 23½" wide, 21" deep. **\$99.50** F. O. B. Factories Tax Extra



Model C-55
5½ cu. ft. NET Capacity. 10½ sq. ft. Shelf Area. Dimensions: 35½" high, 21½" wide, 21½" deep. **\$139.50** F. O. B. Factories Tax Extra

The Crosley Electric Refrigerators at amazingly low prices and with modern, up-to-date refrigeration features have from their very introduction attained outstanding success. Housewives and apartment owners everywhere have been high in their praise of the Crosley models which meet every refrigeration need and sell at astonishingly low prices. See your Crosley Distributor for more details about the Crosley Refrigerators.

Montana, Wyoming, Colorado, New Mexico and West, prices slightly higher

THE CROSLEY RADIO CORPORATION

Powel Crosley, Jr., President

Home of "the Nation's Station"—WLW

CINCINNATI

YOU'RE THERE WITH A CROSLEY

CROSLEY RADIO



The
Cunningham
RADIO TUBE

BIG FIVE PLAN

The Cunningham Radio Tube Big Five Plan is virtually an operating manual for the ambitious dealer to help him develop his radio tube business and increase his store profits. The Big Five plan not only offers helpful and successful sales plans and ideas but also suggests the available material which, when used properly, will make radio tube sales come more easily.

This comprehensive and thoroughly complete plan offers you assistance in your problems of Store Merchandising, Direct Mail,

House-to-House Selling, Radio Service Merchandising and Telephone Selling. It offers you an array of new and up to the minute material with sales producing power that has been pre-tested. New window displays, counter cards, streamers, muslin banners, carrying cartons, log books, door openers, post cards, broadsides, hand bills, service plans, novelties and many other sales aids have been designed to sell more Cunningham radio tubes.

E. T. CUNNINGHAM, INC. • HARRISON, N. J.
A Radio Corporation of America Subsidiary